

# Grooving, Profiling, and Cut-Off

<b>Grooving, Profiling, and Cut-Off Inserts</b> .....	GP 02-18
Grade Descriptions.....	GP 04
Insert Grade Reference.....	GP 06
Pictorial Index.....	GP 07
Inserts.....	GP 08-18
<b>Toolholders and Bars</b> .....	GP 19-38
Pictorial Index.....	GP 20-21
Toolholders and Bars.....	GP 22-38
<b>Support Blades</b> .....	GP 39-53
Support Blade Overview .....	GP 40-41
Support Blades .....	GP 42-53



**SIFOM**

114-116 Boulevard Voltaire  
F - 75543 Paris Cedex 11  
www.sifom.fr

Tél. : +33 (0)1 48 05 87 46  
Fax : +33 (0)1 48 06 07 90  
email : sifom@sifom.fr



## Grooving, Profiling and Cut-Off Inserts

Greenleaf offers one of the most comprehensive lines of grooving, profiling, and cut-off inserts in the industry. The single-ended V-bottom grooving systems allow greater depth of cut and optimal transfer of cutting forces for carbide and ceramic inserts.

Our advanced MT-CVD-coated and PVD-coated grades have the strength and wear resistance needed for higher cutting speeds and tool life.

Greenleaf is the industry leader in the development and manufacture of ceramic and coated ceramic inserts, including WG-600® and WG-700™ – second-generation, coated ceramic-composite cutting tools using whisker reinforcement. The coatings protect the already heat-resistant substrate from additional heat encountered in grooving applications and appreciably extend tool life.



# Insert Grades

## Carbide

### CVD Coated

#### GA5025

A high-speed MT-CVD coated grade developed primarily for turning, GA5025 excels in light roughing and finishing applications of carbon and alloy steels, including select stainless steels. GA5025 is preferred in grooving and profiling applications where tool life and wear resistance are essential.

#### GA5026

A high-performance grade specifically developed for finish-turning in nickel- and cobalt-based super-alloys, stainless steels, hardened steels, and refractory metals. The combination of an advanced MT-CVD coating over a hard, sub-micron grain carbide offers outstanding wear resistance while maintaining exceptional resistance to notching and deformation common in turning of high-strength materials. GA5026 is best applied at high speeds and low feed rates.

#### GA5035

A high-performance MT-CVD coated grade for turning in all types of steels, GA5035 can be used from rough to finish-turning applications that require resistance to heat deformation and abrasion. GA5035 is the primary choice for steel grooving and profiling applications, and should be applied at high speeds and moderate feed rates.

#### GA5036

A high-speed MT-CVD coated grade developed primarily for milling, GA5036 excels in grooving and profiling applications of forged and cast steels, as well as select stainless steels where toughness and heat resistance are required. GA5036 is best applied at high cutting speeds and moderate feed rates.

#### GA5125

A high-performance MT-CVD coated carbide grade developed specifically for milling manganese steel, GA5125 can also be applied to interrupted and continuous grooving and profiling applications in chrome-moly steel, tool steel and similar high alloy steels. GA5125 offers excellent wear, built-up edge, thermal shock and deformation resistance, and is best applied at high cutting speeds with moderate feed rates.

### PVD Coated

#### G-915

A tough PVD-coated grade, G-915 is exceptional for milling and interrupted turning of heat-resistant alloys, stainless steels and low-carbon steels. The multi-layer PVD coating provides heat and abrasion resistance to the tough substrate, making G-915 a versatile grade choice that performs well in a variety of materials and grooving, profiling and cut-off applications. G-915 is best applied at moderate speeds and moderate-to-high feed rates.

#### G-920

A high-speed PVD-coated grade for light-to-medium turning applications of heat-resistant alloys and select stainless steels, G-920 is also an excellent grade option for machining aluminum and refractory metals. The resistance to deformation and notching which allows the use of high cutting speeds makes G-920 well-suited to grooving and finish profiling applications in heat-resistant alloys.

#### G-925

A high-performance multi-layered PVD-coated grade, G-925 is specifically designed for machining abrasive and difficult-to-machine materials. Typical applications include grooving and profiling of heat-resistant alloys, titanium, and other refractory metals, stainless steels, and ductile cast irons. G-925 exhibits excellent resistance to notching and deformation, and should be applied at moderate-to-high speeds and moderate feed rates.

#### G-935

A multi-layer PVD-coated grade primarily for steel milling and turning applications requiring additional resistance to mechanical and thermal shock. These properties make G-935 an ideal choice in grooving and profiling applications where toughness is essential. G-935 is best applied at high cutting speeds and moderate feed rates.

#### G-9610

An advanced PVD-coated grade, G-9610 is specifically designed for turning, grooving and profiling applications in all grades of titanium. The high-tech coating provides wear-resistance, chemical stability and a smooth, lubricious outer layer which protects the hard, sub-micron grain substrate and enables high cutting speeds and extended tool life for continuous cuts in non-ferrous alloys.

### Uncoated

#### G-10

A medium grain carbide grade suited for the medium-to-heavy roughing of titanium and Heat-Resistant Super Alloys.

#### G-20M

A sub-micron C-2 carbide grade suited for use in light-to-medium turning, grooving and profiling of titanium and heat-resistant super alloys. G-20M has the edge strength and edge wear characteristics necessary to resist notching when grooving high-strength materials.

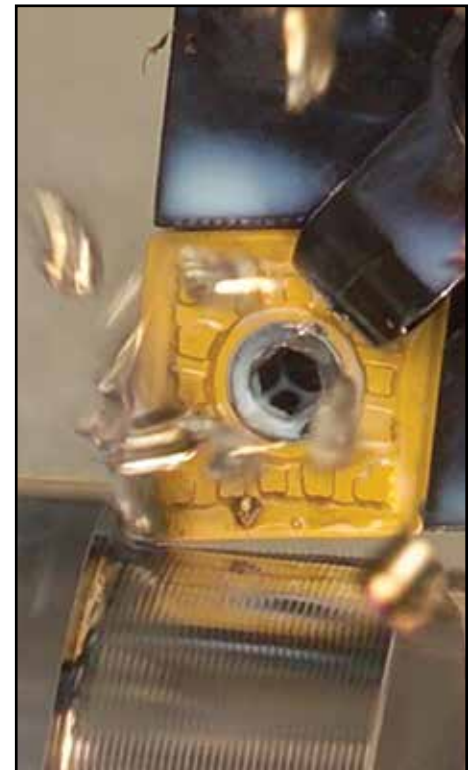

## Ceramic

### WG-300®

A SiC whisker-reinforced  $Al_2O_3$  ceramic that is very effective at machining nickel- and cobalt-based super alloys, alloyed cast iron, and hardened steels at metal removal rates up to 10 times higher than carbide. Excellent chemical stability and wear resistance at very high cutting speeds make WG-300® the first choice worldwide for grooving difficult materials.

### WG-600®

A coated SiC whisker-reinforced  $Al_2O_3$  ceramic that offers higher tool life and speed capabilities than uncoated whisker-reinforced ceramics due to the additional barrier to heat and mechanical abrasion. Application areas for WG-600® include rough and finish turning of alloys in the M, K, S, and H ISO material classes, as well as grooving of hardened steels and select stainless steels. WG-600® is particularly well-suited for finish-turning and grooving of heat-resistant super alloys and is unmatched in both grooving and milling of steels with a hardness above 60 HRC.

### WG-700™

A SiC whisker-reinforced  $Al_2O_3$  ceramic featuring improved toughness and a unique low-friction coating. WG-700™ is ideal for turning, grooving, and profiling nickel- and cobalt-based super alloys that other ceramics may struggle in. WG-700™ exhibits exceptional tool life and productivity in next-generation formulations or novel heat treatments of heat-resistant super alloys lower, and long-reach or thin-walled applications with lower rigidity.

### XSYTIN®-1

A phase-toughened ceramic grade capable of sustaining extreme cutting forces. The unprecedented strength, impact toughness, and resistance to thermal shock of XSYTIN®-1 make it ideal for use in interrupted turning, forging scale removal and milling. In continuous cuts, the strength of XSYTIN®-1 allows the use of significantly higher feed rates or depths of cut. In machining environments with severe interruptions and scale, the edge strength of XSYTIN®-1 allows the use of very light edge preparations, minimizing the force of impact and making for a much smoother cut.

### GSN100™

An engineered blend of hot-pressed silicon nitride and proprietary toughening agents that excels in the machining of cast iron. GSN100™ delivers superior wear and toughness for turning, grooving, and milling applications. It is available in all standard geometries and engineered specials.

### GEM-8™

An  $Al_2O_3 + TiC$  composite ceramic exhibiting excellent hardness and strength at elevated temperatures. GEM-8™ offers a high degree of predictability in roll turning and continuous cuts in ferrous alloys.



# Insert Grade Reference for Grooving, Profiling, and Cut-Off

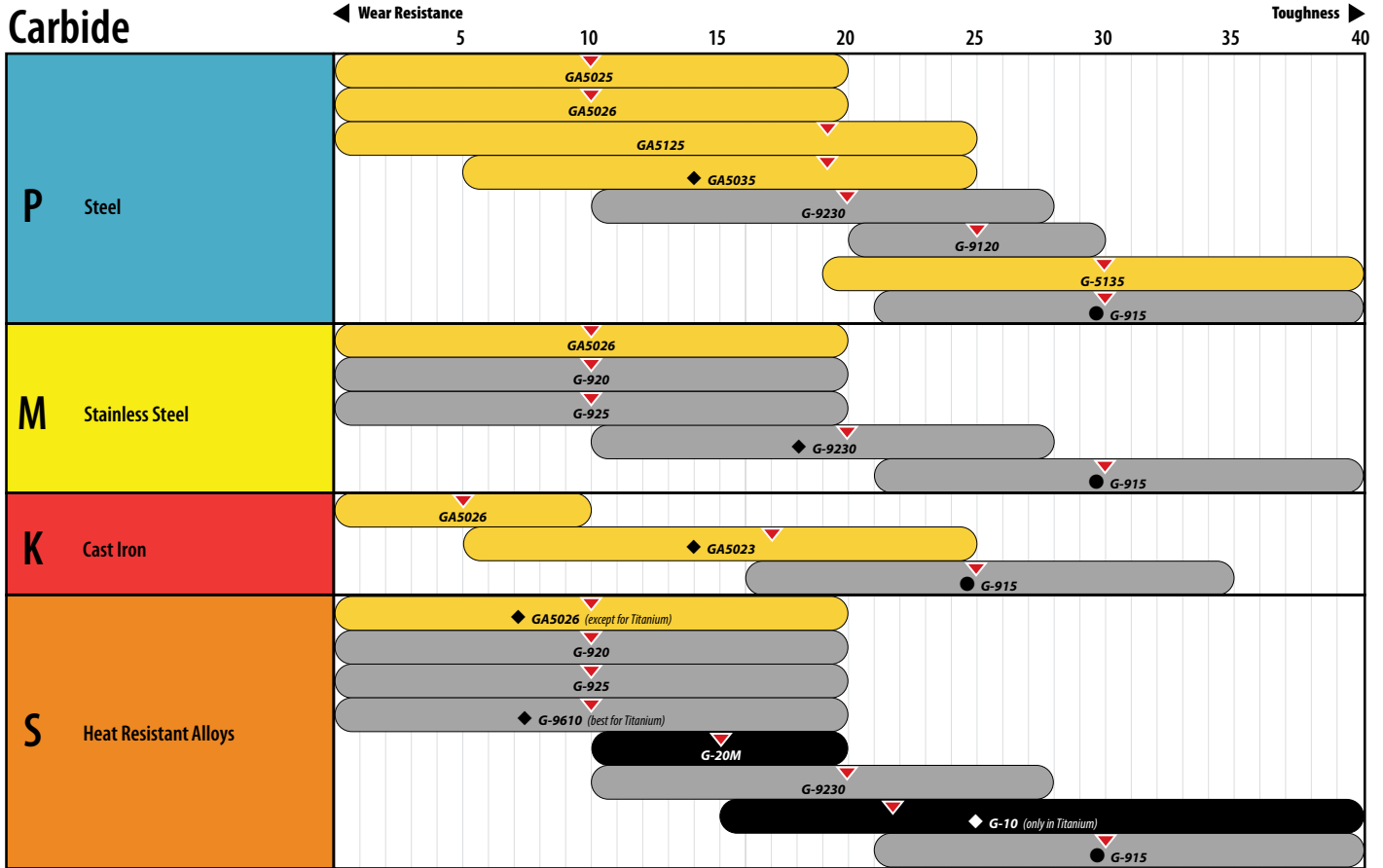

CARBIDE COATINGS: MT-CVD Coated PVD Coated Uncoated First Choice Second Choice

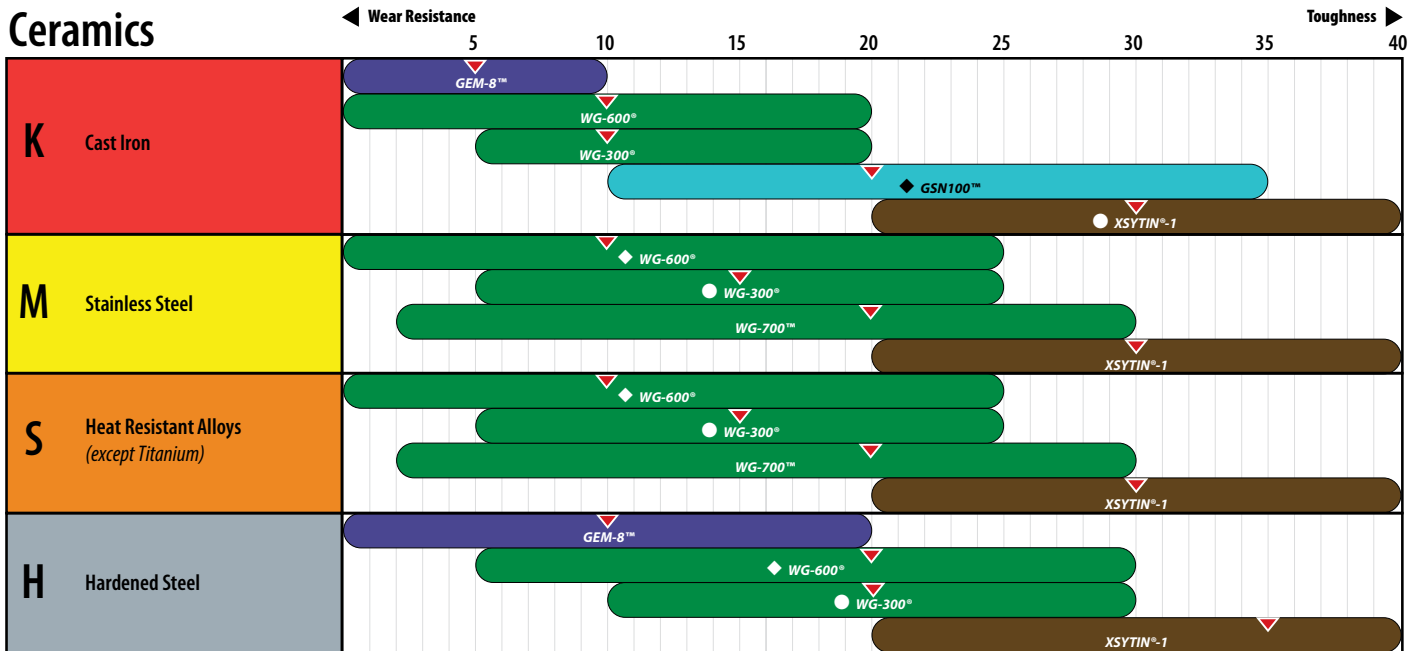

CERAMIC CLASSIFICATION: Whisker Ceramic Phase-Toughened Silicon Nitride Alumina TiC First Choice Second Choice

GROOVING, PROFILING, and CUT-OFF

# Pictorial Index

## Greenleaf Cut-Off System

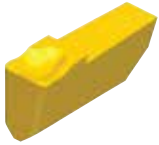

COS  
page: GP 08

## V-Bottom Round Inserts

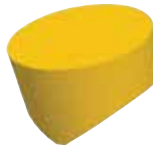

RCGX  
Positive: Carbide  
page: GP 14

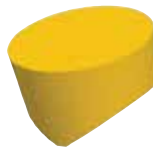

RCGX  
Positive: Ceramic  
page: GP 14

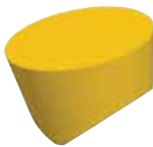

RPGX  
Positive: Carbide  
page: GP 15

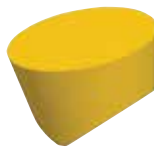

RPGX  
Positive: Ceramic  
page: GP 15



RCGR/RPGR  
Positive Chipform  
V-Bottom  
page: GP 16

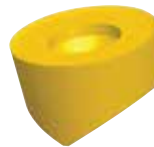

RCGT/RPGT  
Positive Chipform  
V-Bottom  
page: GP 17

## Pulley and Poly Groove Inserts

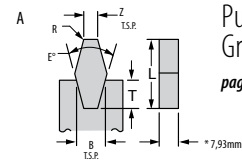

Pulley and Poly  
Groove Inserts  
page: GP 18

## Single-Ended Groovers



GTS Style  
Full Nose  
page: GP 09

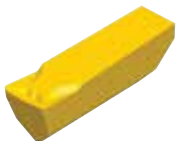

GTS Style  
Flat Nose  
page: GP 09



WG-Style  
Full Nose  
page: GP 10



WG-Style  
Flat Nose  
page: GP 11



WGC  
Full Nose  
page: GP 12



WGC  
Flat Nose  
page: GP 13

# Greenleaf Cut-Off System

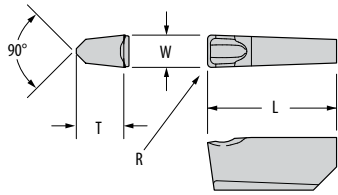

0° Lead

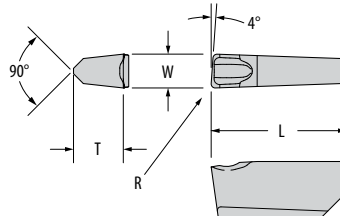

4° Left Hand

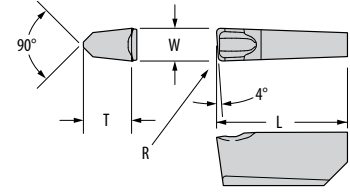

4° Right Hand

Shape: Groove/Turn	Part Number ISO	G-915	Part Number ANSI	Dimensions (mm)			
				W	L	T	R
	COS-4094-0	◆	COS-4094-0	2,39	12,70	4,75	0,25
	COS-4125-0	◆	COS-4125-0	3,18	12,70	4,75	0,25
	COS-4187-0	◆	COS-4187-0	4,75	12,70	4,75	0,25
	COS-4094-4L	◆	COS-4094-4L	2,39	12,70	4,75	0,25
	COS-4125-4L	◆	COS-4125-4L	3,18	12,70	4,75	0,25
	COS-4187-4L	◆	COS-4187-4L	4,75	12,70	4,75	0,25
	COS-4094-4R	◆	COS-4094-4R	2,39	12,70	4,75	0,25
	COS-4125-4R	◆	COS-4125-4R	3,18	12,70	4,75	0,25
	COS-4187-4R	◆	COS-4187-4R	4,75	12,70	4,75	0,25

CARBIDE COATINGS: ■ MF-CVD Coated ■ PVD Coated ■ Uncoated

First Choice ◆ Second Choice ● Alternative ▲ Interrupted/Milling ✦

Grade descriptions — pages GP 04

See pages GP 31, GP 34 and GP 39 for toolholders.

GROOVING, PROFILING, and CUT-OFF



# GTS Style, Full Nose Grooving Inserts

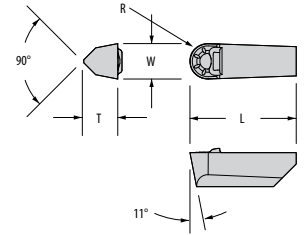

Shape: Groove/Turn	Part Number ISO	Steel		Stainless Steel		Cast Iron		Heat Resistant Super Alloys		Part Number ANSI	Dimensions (mm)			
		P		M		K		S			W	L	T	R
		GA5035	G-915	G-935	GA5026	G-915	G-915	GA5026	G-925					
	GTS-4125	▲	◆	●	◆	●	◆	●	◆	GTS-4125	3,18	12,70	4,75	1,59
	GTS-4187	▲	◆	●	◆	●	◆	●	◆	GTS-4187	4,75	12,70	4,75	2,37
	GTS-6250	▲	◆	●	◆	●	◆	●	◆	GTS-6250	6,35	19,05	6,35	3,18

CARBIDE COATINGS: MF-CVD Coated PVD Coated Uncoated

First Choice ◆ Second Choice ● Alternative ▲ Interrupted/Milling ◇

Grade descriptions — pages GP 04

# GTS Style, Flat Nose Grooving Inserts

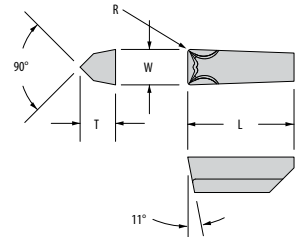

Shape: Groove/Turn	Part Number ISO	Steel		Stainless Steel		Cast Iron		Heat Resistant Super Alloys		Part Number ANSI	Dimensions (mm)			
		P		M		K		S			W	L	T	R
		GA5035	G-915	G-935	GA5026	G-915	G-915	GA5026	G-925					
	GTS-4125-1	▲	◆	●	◆	●	◆	●	◆	GTS-4125-1	3,18	12,70	4,75	0,38
	GTS-4125-2	▲	◆	●	◆	●	◆	●	◆	GTS-4125-2	3,18	12,70	4,75	0,79
	GTS-4187-1	▲	◆	●	◆	●	◆	●	◆	GTS-4187-1	4,75	12,70	4,75	0,38
	GTS-4187-2	▲	◆	●	◆	●	◆	●	◆	GTS-4187-2	4,75	12,70	4,75	0,79
	GTS-6250-1	▲	◆	●	◆	●	◆	●	◆	GTS-6250-1	6,35	19,05	6,35	0,38
	GTS-6250-2	▲	◆	●	◆	●	◆	●	◆	GTS-6250-2	6,35	19,05	6,35	0,79

CARBIDE COATINGS: MF-CVD Coated PVD Coated Uncoated

First Choice ◆ Second Choice ● Alternative ▲ Interrupted/Milling ◇

Grade descriptions — pages GP 04

GROOVING, PROFILING, and CUT-OFF

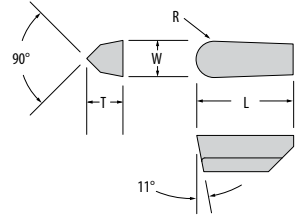

# WG-Style, Full Nose Grooving Inserts

Shape: Groover	Part Number ISO	S Steel		Cast Iron		Heat-Resistant Super Alloys				Hardened Steel				Part Number ANSI	Dimensions (mm)			
		M		K		S				H					W	L	T	R
		WG-600	GSN100	XSYTIN-1	WG-600	WG-300	WG-600	WG-700	XSYTIN-1	WG-300	WG-600	XSYTIN-1	GEM-8					
	WG-4094	◆	◆	▲	●	●	◆	▲	▲	●	●	❖	▲	WG-4094	2,39	12,70	4,75	1,19
	WG-4125	◆	◆	▲	●	●	◆	▲	▲	●	●	❖	▲	WG-4125	3,18	12,70	4,75	1,59
	WG-4156	◆	◆	▲	●	●	◆	▲	▲	●	●	❖	▲	WG-4156	3,96	12,70	4,75	1,98
	WG-4187	◆	◆	▲	●	●	◆	▲	▲	●	●	❖	▲	WG-4187	4,75	12,70	4,75	2,37
	WG-6218	◆	◆	▲	●	●	◆	▲	▲	●	●	❖	▲	WG-6218	5,54	19,05	6,35	2,77
	WG-6250	◆	◆	▲	●	●	◆	▲	▲	●	●	❖	▲	WG-6250	6,35	19,05	6,35	3,18
	WG-6281	◆	◆	▲	●	●	◆	▲	▲	●	●	❖	▲	WG-6281	7,14	19,05	6,35	3,57
	WG-8312	◆	◆	▲	●	●	◆	▲	▲	●	●	❖	▲	WG-8312	7,93	25,40	8,56	3,96
	WG-8344	◆	◆	▲	●	●	◆	▲	▲	●	●	❖	▲	WG-8344	8,74	25,40	8,56	4,37
	WG-8375	◆	◆	▲	●	●	◆	▲	▲	●	●	❖	▲	WG-8375	9,53	25,40	8,56	4,76

CERAMIC CLASSIFICATION: Whisker Ceramic Phase-Toughened Silicon Nitride Alumina TiC First Choice ◆ Second Choice ● Alternative ▲ Interrupted/Milling ❖ Grade descriptions — pages GP 05

GROOVING, PROFILING, and CUT-OFF

# WG-Style, Flat Nose Grooving Inserts

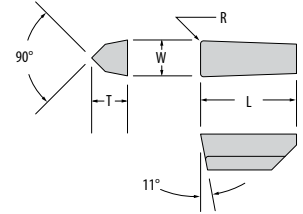

Shape: Groover	Part Number ISO	S Steel	Cast Iron				Heat-Resistant Super Alloys				Hardened Steel				Part Number ANSI	Dimensions (mm)			
		M	K			S				H				W		L	T	R	
		WG-600	GSN100	XSYTIN-1	WG-600	WG-300	WG-600	WG-700	XSYTIN-1	WG-300	WG-600	XSYTIN-1	GEM-8						
	WG-4094-1	◆	◆	▲	●	●	◆	▲	▲	●	●	❖	▲	WG-4094-1	2,39	12,70	4,75	0,38	
	WG-4094-2	◆	◆	▲	●	●	◆	▲	▲	●	●	❖	▲	WG-4094-2	2,39	12,70	4,75	0,79	
	WG-4125-1	◆	◆	▲	●	●	◆	▲	▲	●	●	❖	▲	WG-4125-1	3,18	12,70	4,75	0,38	
	WG-4125-2	◆	◆	▲	●	●	◆	▲	▲	●	●	❖	▲	WG-4125-2	3,18	12,70	4,75	0,79	
	WG-4156-1	◆	◆	▲	●	●	◆	▲	▲	●	●	❖	▲	WG-4156-1	3,96	12,70	4,75	0,38	
	WG-4156-2	◆	◆	▲	●	●	◆	▲	▲	●	●	❖	▲	WG-4156-2	3,96	12,70	4,75	0,79	
	WG-4156-3	◆	◆	▲	●	●	◆	▲	▲	●	●	❖	▲	WG-4156-3	3,96	12,70	4,75	1,17	
	WG-4187-1	◆	◆	▲	●	●	◆	▲	▲	●	●	❖	▲	WG-4187-1	4,75	12,70	4,75	0,38	
	WG-4187-2	◆	◆	▲	●	●	◆	▲	▲	●	●	❖	▲	WG-4187-2	4,75	12,70	4,75	0,79	
	WG-6218-1	◆	◆	▲	●	●	◆	▲	▲	●	●	❖	▲	WG-6218-1	5,54	19,05	6,35	0,38	
	WG-6218-2	◆	◆	▲	●	●	◆	▲	▲	●	●	❖	▲	WG-6218-2	5,54	19,05	6,35	0,79	
	WG-6250-1	◆	◆	▲	●	●	◆	▲	▲	●	●	❖	▲	WG-6250-1	6,35	19,05	6,35	0,38	
	WG-6250-2	◆	◆	▲	●	●	◆	▲	▲	●	●	❖	▲	WG-6250-2	6,35	19,05	6,35	0,79	
	WG-6250-3	◆	◆	▲	●	●	◆	▲	▲	●	●	❖	▲	WG-6250-3	6,35	19,05	6,35	1,17	
	WG-6250-4	◆	◆	▲	●	●	◆	▲	▲	●	●	❖	▲	WG-6250-4	6,35	19,05	6,35	1,57	
	WG-6281-1	◆	◆	▲	●	●	◆	▲	▲	●	●	❖	▲	WG-6281-1	7,14	19,05	6,35	0,38	
	WG-6281-2	◆	◆	▲	●	●	◆	▲	▲	●	●	❖	▲	WG-6281-2	7,14	19,05	6,35	0,79	
	WG-6281-3	◆	◆	▲	●	●	◆	▲	▲	●	●	❖	▲	WG-6281-3	7,14	19,05	6,35	1,17	
	WG-8312-1	◆	◆	▲	●	●	◆	▲	▲	●	●	❖	▲	WG-8312-1	7,92	25,40	8,56	0,38	
	WG-8312-2	◆	◆	▲	●	●	◆	▲	▲	●	●	❖	▲	WG-8312-2	7,92	25,40	8,56	0,79	
	WG-8312-3	◆	◆	▲	●	●	◆	▲	▲	●	●	❖	▲	WG-8312-3	7,92	25,40	8,56	1,17	
	WG-8312-4	◆	◆	▲	●	●	◆	▲	▲	●	●	❖	▲	WG-8312-4	7,92	25,40	8,56	1,57	
	WG-8344-1	◆	◆	▲	●	●	◆	▲	▲	●	●	❖	▲	WG-8344-1	8,74	25,40	8,56	0,38	
	WG-8344-2	◆	◆	▲	●	●	◆	▲	▲	●	●	❖	▲	WG-8344-2	8,74	25,40	8,56	0,79	
	WG-8344-3	◆	◆	▲	●	●	◆	▲	▲	●	●	❖	▲	WG-8344-3	8,74	25,40	8,56	1,17	
	WG-8344-4	◆	◆	▲	●	●	◆	▲	▲	●	●	❖	▲	WG-8344-4	8,74	25,40	8,56	1,57	
	WG-8375-1	◆	◆	▲	●	●	◆	▲	▲	●	●	❖	▲	WG-8375-1	9,53	25,40	8,56	0,38	
	WG-8375-2	◆	◆	▲	●	●	◆	▲	▲	●	●	❖	▲	WG-8375-2	9,53	25,40	8,56	0,79	
	WG-8375-3	◆	◆	▲	●	●	◆	▲	▲	●	●	❖	▲	WG-8375-3	9,53	25,40	8,56	1,17	
	WG-8375-4	◆	◆	▲	●	●	◆	▲	▲	●	●	❖	▲	WG-8375-4	9,53	25,40	8,56	1,57	



CERAMIC CLASSIFICATION: Whisker Ceramic Phase-Toughened Silicon Nitride Alumina TiC First Choice ◆ Second Choice ● Alternative ▲ Interrupted/Milling ❖ Grade descriptions — pages GP 05

GROOVING, PROFILING, and CUT-OFF

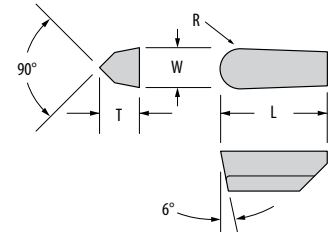

# WGC, Full Nose Grooving Inserts

Shape: Groover	Part Number ISO	S Steel		Cast Iron		Heat-Resistant Super Alloys				Hardened Steel				Part Number ANSI	Dimensions (mm)			
		M	K	S				H				W	L		T	R		
		WG-600	GSN100	XSYTIN-1	WG-600	WG-300	WG-600	WG-700	XSYTIN-1	WG-300	WG-600						XSYTIN-1	GEM-8
	WGC-4094	◆	◆	▲	●	●	◆	▲	▲	●	●	❖	▲	WGC-4094	2,39	12,70	4,75	1,19
	WGC-4125	◆	◆	▲	●	●	◆	▲	▲	●	●	❖	▲	WGC-4125	3,18	12,70	4,75	1,59
	WGC-4156	◆	◆	▲	●	●	◆	▲	▲	●	●	❖	▲	WGC-4156	3,96	12,70	4,75	1,98
	WGC-4187	◆	◆	▲	●	●	◆	▲	▲	●	●	❖	▲	WGC-4187	4,75	12,70	4,75	2,37
	WGC-6218	◆	◆	▲	●	●	◆	▲	▲	●	●	❖	▲	WGC-6218	5,54	19,05	6,35	2,77
	WGC-6250	◆	◆	▲	●	●	◆	▲	▲	●	●	❖	▲	WGC-6250	6,35	19,05	6,35	3,18
	WGC-6281	◆	◆	▲	●	●	◆	▲	▲	●	●	❖	▲	WGC-6281	7,14	19,05	6,35	3,57
	WGC-8312	◆	◆	▲	●	●	◆	▲	▲	●	●	❖	▲	WGC-8312	7,93	25,40	8,56	3,96
	WGC-8344	◆	◆	▲	●	●	◆	▲	▲	●	●	❖	▲	WGC-8344	8,74	25,40	8,56	4,37
	WGC-8375	◆	◆	▲	●	●	◆	▲	▲	●	●	❖	▲	WGC-8375	9,53	25,40	8,56	4,76

CERAMIC CLASSIFICATION: Whisker Ceramic Phase-Toughened Silicon Nitride Alumina TiC First Choice ◆ Second Choice ● Alternative ▲ Interrupted/Milling ❖ Grade descriptions — pages GP 05

GROOVING, PROFILING, and CUT-OFF

# WGC, Flat Nose Grooving Inserts

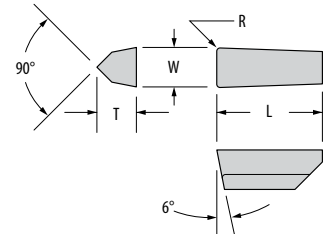

Shape: Groover	Part Number ISO	S Steel	Cast Iron				Heat-Resistant Super Alloys				Hardened Steel				Part Number ANSI	Dimensions (mm)			
		M	K			S				H				W		L	T	R	
		WG-600	GSN 100	XSYTIN-1	WG-600	WG-300	WG-600	WG-700	XSYTIN-1	WG-300	WG-600	XSYTIN-1	GEM-8						
WGC-4094-1	◆	◆	▲	●	●	◆	▲	▲	●	●	◆	▲	WGC-4094-1	2,39	12,70	4,75	0,38		
WGC-4094-2	◆	◆	▲	●	●	◆	▲	▲	●	●	◆	▲	WGC-4094-2	2,39	12,70	4,75	0,79		
WGC-4125-1	◆	◆	▲	●	●	◆	▲	▲	●	●	◆	▲	WGC-4125-1	3,18	12,70	4,75	0,38		
WGC-4125-2	◆	◆	▲	●	●	◆	▲	▲	●	●	◆	▲	WGC-4125-2	3,18	12,70	4,75	0,79		
WGC-4156-1	◆	◆	▲	●	●	◆	▲	▲	●	●	◆	▲	WGC-4156-1	3,96	12,70	4,75	0,38		
WGC-4156-2	◆	◆	▲	●	●	◆	▲	▲	●	●	◆	▲	WGC-4156-2	3,96	12,70	4,75	0,79		
WGC-4187-1	◆	◆	▲	●	●	◆	▲	▲	●	●	◆	▲	WGC-4187-1	4,75	12,70	4,75	0,38		
WGC-4187-2	◆	◆	▲	●	●	◆	▲	▲	●	●	◆	▲	WGC-4187-2	4,75	12,70	4,75	0,79		
WGC-6218-1	◆	◆	▲	●	●	◆	▲	▲	●	●	◆	▲	WGC-6218-1	5,54	19,05	6,35	0,38		
WGC-6218-2	◆	◆	▲	●	●	◆	▲	▲	●	●	◆	▲	WGC-6218-2	5,54	19,05	6,35	0,79		
WGC-6250-1	◆	◆	▲	●	●	◆	▲	▲	●	●	◆	▲	WGC-6250-1	6,35	19,05	6,35	0,38		
WGC-6250-2	◆	◆	▲	●	●	◆	▲	▲	●	●	◆	▲	WGC-6250-2	6,35	19,05	6,35	0,79		
WGC-6250-3	◆	◆	▲	●	●	◆	▲	▲	●	●	◆	▲	WGC-6250-3	6,35	19,05	6,35	1,17		
WGC-6281-1	◆	◆	▲	●	●	◆	▲	▲	●	●	◆	▲	WGC-6281-1	7,14	19,05	6,35	0,38		
WGC-6281-2	◆	◆	▲	●	●	◆	▲	▲	●	●	◆	▲	WGC-6281-2	7,14	19,05	6,35	0,79		
WGC-6281-3	◆	◆	▲	●	●	◆	▲	▲	●	●	◆	▲	WGC-6281-3	7,14	19,05	6,35	1,17		
WGC-8312-1	◆	◆	▲	●	●	◆	▲	▲	●	●	◆	▲	WGC-8312-1	7,92	25,40	8,56	0,38		
WGC-8312-2	◆	◆	▲	●	●	◆	▲	▲	●	●	◆	▲	WGC-8312-2	7,92	25,40	8,56	0,79		
WGC-8312-3	◆	◆	▲	●	●	◆	▲	▲	●	●	◆	▲	WGC-8312-3	7,92	25,40	8,56	1,17		
WGC-8312-4	◆	◆	▲	●	●	◆	▲	▲	●	●	◆	▲	WGC-8312-4	7,92	25,40	8,56	1,57		
WGC-8344-1	◆	◆	▲	●	●	◆	▲	▲	●	●	◆	▲	WGC-8344-1	8,74	25,40	8,56	0,38		
WGC-8344-2	◆	◆	▲	●	●	◆	▲	▲	●	●	◆	▲	WGC-8344-2	8,74	25,40	8,56	0,79		
WGC-8344-3	◆	◆	▲	●	●	◆	▲	▲	●	●	◆	▲	WGC-8344-3	8,74	25,40	8,56	1,17		
WGC-8344-4	◆	◆	▲	●	●	◆	▲	▲	●	●	◆	▲	WGC-8344-4	8,74	25,40	8,56	1,57		
WGC-8375-1	◆	◆	▲	●	●	◆	▲	▲	●	●	◆	▲	WGC-8375-1	9,53	25,40	8,56	0,38		
WGC-8375-2	◆	◆	▲	●	●	◆	▲	▲	●	●	◆	▲	WGC-8375-2	9,53	25,40	8,56	0,79		
WGC-8375-3	◆	◆	▲	●	●	◆	▲	▲	●	●	◆	▲	WGC-8375-3	9,53	25,40	8,56	1,17		
WGC-8375-4	◆	◆	▲	●	●	◆	▲	▲	●	●	◆	▲	WGC-8375-4	9,53	25,40	8,56	1,57		



CERAMIC CLASSIFICATION: Whisker Ceramic Phase-Toughened Silicon Nitride Alumina TiC First Choice ◆ Second Choice ● Alternative ▲ Interrupted/Milling ◆ Grade descriptions — pages GP 05

GROOVING, PROFILING, and CUT-OFF

# Round Positive V-Bottom Inserts

RCGX-V — Carbide

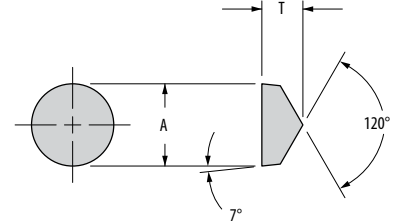

Shape: Round V-Bottom	Part Number ISO	Steel				Stainless Steel		Cast Iron	Heat-Resistant Super Alloys						Part Number ANSI	Dimensions (mm)			
		P				M		K	S							A	T		
		GA5025	GA5035	GA5125	GA5036	GA5026	G-925	G-915	GA5023	G-915	G-10	GA5026	G-9610	G-925				G-920	G-20M
	RCGX-060400	●	◆	▲	❖	●	◆	❖	◆	❖	❖	●	▲	◆	▲	▲	RCGN-2V	6,35	4,75
	RCGX-060600	●	◆	▲	❖	●	◆	❖	◆	❖	❖	●	▲	◆	▲	▲	RCGX-102	6,35	6,35
	RCGX-090700	●	◆	▲	❖	●	◆	❖	◆	❖	❖	●	▲	◆	▲	▲	RCGN-3V	9,53	7,92
	RCGX-120700	●	◆	▲	❖	●	◆	❖	◆	❖	❖	●	▲	◆	▲	▲	RCGN-4V	12,70	7,92

CARBIDE COATINGS: MF-CVD Coated PVD Coated Uncoated

First Choice ◆ Second Choice ● Alternative ▲ Interrupted/Milling ❖

Grade descriptions — pages GP 04

# Round Positive V-Bottom Inserts

RCGX-V — Ceramic

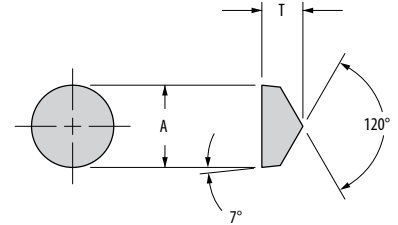

Shape: Round V-Bottom	Part Number ISO	S Steel	Cast Iron		Heat-Resistant Super Alloys				Hardened Steel				Part Number ANSI	Dimensions (mm)		
		M	K		S				H					A	T	
		WG-600	GSNT100	XYTYN-1	WG-600	WG-300	WG-600	WG-700	XYTYN-1	WG-300	WG-600	XYTYN-1				GEM-8
	RCGX-060400	◆	◆	▲	●	●	◆	▲	▲	●	●	❖	▲	RCGN-2V	6,35	4,75
	RCGX-060600	◆	◆	▲	●	●	◆	▲	▲	●	●	❖	▲	RCGN-102	6,35	6,35
	RCGX-090700	◆	◆	▲	●	●	◆	▲	▲	●	●	❖	▲	RCGN-3V	9,53	7,92
	RCGX-120700	◆	◆	▲	●	●	◆	▲	▲	●	●	❖	▲	RCGN-4V	12,70	7,92

CERAMIC CLASSIFICATION: Whisker Ceramic Phase-Toughened Silicon Nitride Alumina TiC First Choice ◆ Second Choice ● Alternative ▲ Interrupted/Milling ❖

Grade descriptions — pages GP 05

See pages AT1 22-23 for information on edge preps. For availability and any application concerns, please contact Greenleaf Technical Service.

GROOVING, PROFILING, and CUT-OFF

# Round Positive V-Bottom Inserts

RPGX-V — Carbide

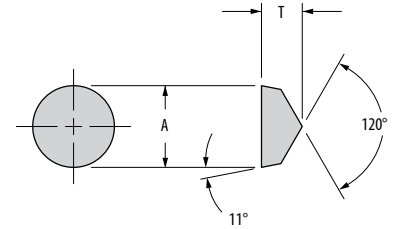

Shape: Round V-Bottom	Part Number ISO	Steel				Stainless Steel		Cast Iron	Heat-Resistant Super Alloys						Part Number ANSI	Dimensions (mm)			
		P				M		K	S							A	T		
		GA5025	GA5035	GA5125	GA5036	GA5026	G-925	G-915	GA5023	G-915	G-10	GA5026	G-9610	G-925				G-920	G-20M
	RPGX-060400	●	◆	▲	❖	●	◆	❖	◆	❖	❖	●	▲	◆	▲	▲	RPGN-2V	6,35	4,75
	RPGX-090700	●	◆	▲	❖	●	◆	❖	◆	❖	❖	●	▲	◆	▲	▲	RPGN-3V	9,53	7,92
	RPGX-120700	●	◆	▲	❖	●	◆	❖	◆	❖	❖	●	▲	◆	▲	▲	RPGN-4V	12,70	7,92

CARBIDE COATINGS: MF-CVD Coated PVD Coated Uncoated

First Choice ◆ Second Choice ● Alternative ▲ Interrupted/Milling ❖

Grade descriptions — pages GP 04

# Round Positive V-Bottom Inserts

RPGX-V — Ceramic

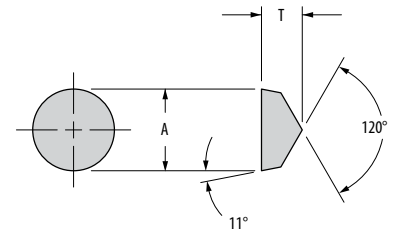

Shape: Round V-Bottom	Part Number ISO	S Steel	Cast Iron		Heat-Resistant Super Alloys				Hardened Steel				Part Number ANSI	Dimensions (mm)		
		M	K		S				H					A	T	
		WG-600	GSNT100	XYTIN-1	WG-600	WG-300	WG-600	WG-700	XYTIN-1	WG-300	WG-600	XYTIN-1				GEM-8
	RPGX-060400	◆	◆	▲	●	●	◆	▲	▲	●	●	❖	▲	RPGN-2V	6,35	4,75
	RPGX-090700	◆	◆	▲	●	●	◆	▲	▲	●	●	❖	▲	RPGN-3V	9,53	7,92
	RPGX-120700	◆	◆	▲	●	●	◆	▲	▲	●	●	❖	▲	RPGN-4V	12,70	7,92

CERAMIC CLASSIFICATION: Whisker Ceramic Phase-Toughened Silicon Nitride Alumina TiC First Choice ◆ Second Choice ● Alternative ▲ Interrupted/Milling ❖

Grade descriptions — pages GP 05

See pages AT1 22-23 for information on edge preps. For availability and any application concerns, please contact Greenleaf Technical Service.

# Round Positive Chipform V-Bottom Inserts

RCGR-V/RPGR-V — Carbide

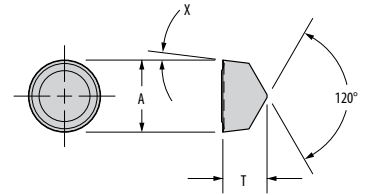

Shape: Round V-Bottom	Part Number ISO	Steel				Stainless Steel		Cast Iron	Heat-Resistant Super Alloys						Part Number ANSI	Dimensions (mm)				
		P				M		K	S							A	T	X		
		GA5025	GA5035	GA5125	GA5036	GA5026	G-925	G-915	GA5023	G-915	G-10	GA5026	G-9610	G-925					G-920	G-20M
	RCGR-060400V-TF					●	◆					●	▲	◆	▲	▲	RCGR-2V-TF	6,35	4,75	7°
	RCGR-090700V-TF					●	◆					●	▲	◆	▲	▲	RCGR-3V-TF	9,53	7,92	7°
	RCGR-120700V-TF					●	◆					●	▲	◆	▲	▲	RCGR-4V-TF	12,70	7,92	7°
	RPGX-060400V-TF					●	◆					●	▲	◆	▲	▲	RPGR-2V-TF	6,35	4,75	11°
	RPGX-090700V-TF					●	◆					●	▲	◆	▲	▲	RPGR-3V-TF	9,53	7,92	11°
	RPGX-120700V-TF					●	◆					●	▲	◆	▲	▲	RPGR-4V-TF	12,70	7,92	11°

CARBIDE COATINGS: MF-CVD Coated PVD Coated Uncoated First Choice ◆ Second Choice ● Alternative ▲ Interrupted/Milling ◇ Grade descriptions — pages GP 04

# Round Positive Chipform V-Bottom Inserts

RCGR-V/RPGR-V — Ceramic

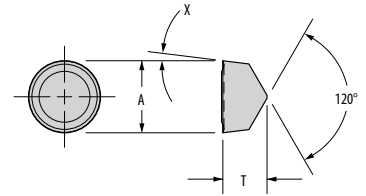

Shape: Round V-Bottom	Part Number ISO	S Steel	Cast Iron	Heat-Resistant Super Alloys				Hardened Steel				Part Number ANSI	Dimensions (mm)			
		M	K	S				H					A	T	X	
		WG-600	GSNT100	XYTIN-1	WG-600	WG-300	WG-600	WG-700	XYTIN-1	WG-300	WG-600					XYTIN-1
	RCGR-060400V-GF1	◆		▲	●	●	◆	▲	▲	●	●	◆	RCGR-2V-GF1	6,35	4,75	7°
	RCGR-090700V-GF1	◆		▲	●	●	◆	▲	▲	●	●	◆	RCGR-3V-GF1	9,53	7,92	7°
	RCGR-120700V-GF1	◆		▲	●	●	◆	▲	▲	●	●	◆	RCGR-4V-GF1	12,70	7,92	7°
	RPGR-060400V-GF1	◆		▲	●	●	◆	▲	▲	●	●	◆	RPGR-2V-GF1	6,35	4,75	11°
	RPGR-090700V-GF1	◆		▲	●	●	◆	▲	▲	●	●	◆	RPGR-3V-GF1	9,53	7,92	11°

CERAMIC CLASSIFICATION: Whisker Ceramic Phase-Toughened Silicon Nitride Alumina TiC First Choice ◆ Second Choice ● Alternative ▲ Interrupted/Milling ◇ Grade descriptions — pages GP 05

GROOVING, PROFILING, and CUT-OFF



# Round Positive Chipform V-Bottom Inserts

RCGT-V — Carbide

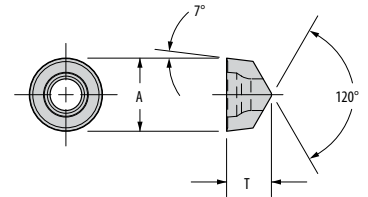

Shape: Round V-Bottom	Part Number ISO	Steel				Stainless Steel		Cast Iron	Heat-Resistant Super Alloys						Part Number ANSI	Dimensions (mm)			
		P				M		K	S							A i.c.	T		
		GA5025	GA5035	GA5125	GA5036	GA5026	G-925	G-915	GA5023	G-915	G-10	GA5026	G-9610	G-925		G-920	G-20M		
	RCGT-060400V-TF					●	◆					●	▲	◆	▲	▲	RCGT-2V-TF	6,35	4,75
	RCGT-090700V-TF					●	◆					●	▲	◆	▲	▲	RCGT-3V-TF	9,53	7,92
	RCGT-120700V-TF					●	◆					●	▲	◆	▲	▲	RCGT-4V-TF	12,70	7,92

CARBIDE COATINGS: MF-CVD Coated PVD Coated Uncoated

First Choice ◆ Second Choice ● Alternative ▲ Interrupted/Milling ◇

Grade descriptions — pages GP 04

# Round Positive Chipform V-Bottom Inserts

RPGT-V — Carbide

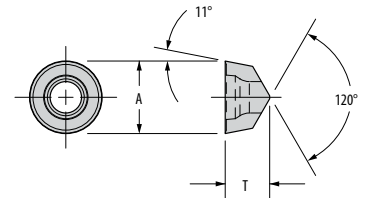

Shape: Round V-Bottom	Part Number ISO	Steel				Stainless Steel		Cast Iron	Heat-Resistant Super Alloys						Part Number ANSI	Dimensions (mm)			
		P				M		K	S							A i.c.	T		
		GA5025	GA5035	GA5125	GA5036	GA5026	G-925	G-915	GA5023	G-915	G-10	GA5026	G-9610	G-925		G-920	G-20M		
	RPGT-060400V-TF					●	◆					●	▲	◆	▲	▲	RPGT-2V-TF	6,35	4,75
	RPGT-090700V-TF					●	◆					●	▲	◆	▲	▲	RPGT-3V-TF	9,53	7,92
	RPGT-120700V-TF					●	◆					●	▲	◆	▲	▲	RPGT-4V-TF	12,70	7,92

CARBIDE COATINGS: MF-CVD Coated PVD Coated Uncoated

First Choice ◆ Second Choice ● Alternative ▲ Interrupted/Milling ◇

Grade descriptions — pages GP 04

# Pulley and Poly Grooving Inserts

When ordering or requesting quotations, you should provide a part print and a sketch with dimensions as indicated in the following format:

Insert Style	B	E°	L
R <sub>1</sub>	R <sub>2</sub>	T	Z

\* Recommended – other specifications available upon request.

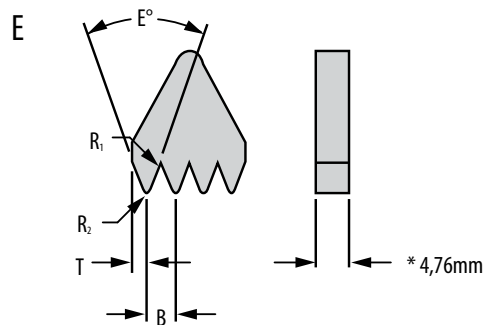
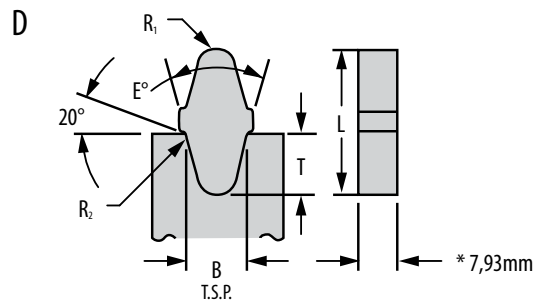
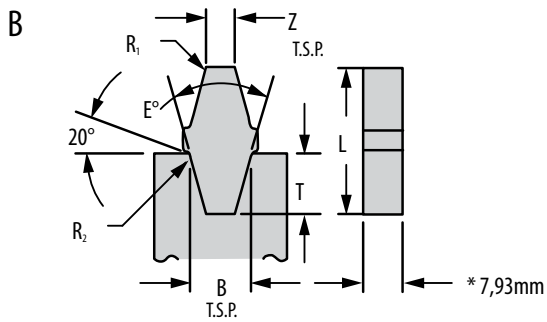
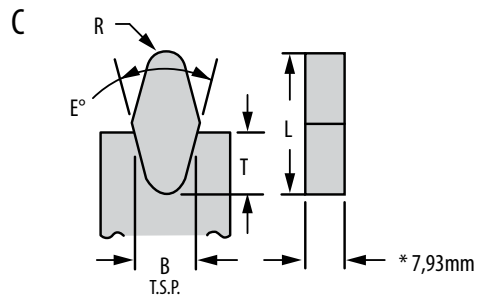
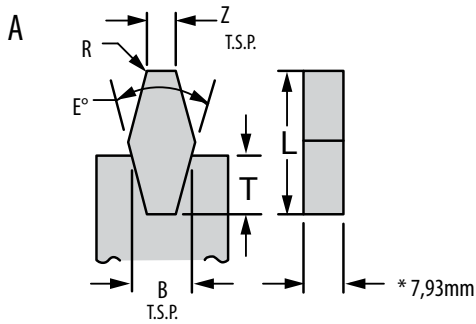

**Z** NUMBER OF TEETH  
REQUIRED ON INSERT

GROOVING, PROFILING, and CUT-OFF

## Grooving, Profiling and Cut-Off Toolholders

The Greenleaf tooling system for grooving, profiling, and cut-off provides every specific application with unsurpassed support to ensure the greatest tool life and highest material-removal rates with both carbide and ceramic inserts. All the tools in this system are designed to use Greenleaf carbide or ceramic inserts interchangeably for maximum versatility.

Toolholders are offered with both milled-nest and replaceable-nest designs to provide further options for your tooling requirements.

Using the most rigid holder that fits the application will make the process more reliable and repeatable, reducing the likelihood of irregular wear.

### Greenleaf Tune-Up Kits

A Tune-Up Kit consists of all the standard hardware to refurbish a particular toolholder, boring bar, or milling cutter. A toolholder will have a readily visible, laser-inscribed Tune-Up Kit number on it for ease in ordering. This number will prevent any confusion created by searching a catalog for hardware, and it will help reduce downtime.

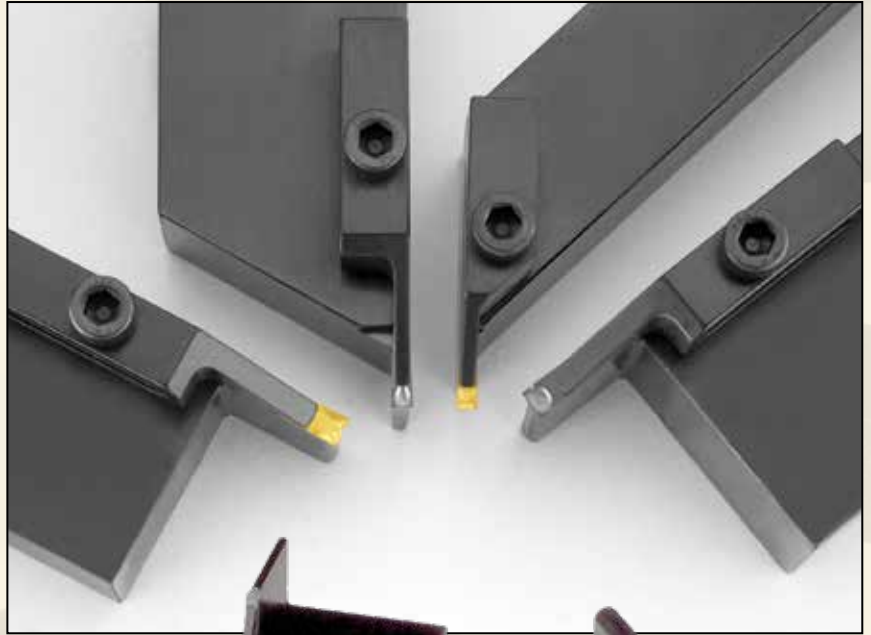

# Pictorial Index

## V-Bottom Round Toolholders

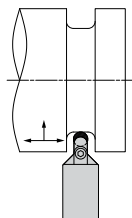

**CRDPN-VS**  
Replaceable Nest  
Shallow D.O.C.  
*page: GP 22*

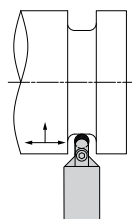

**CRDPN-V**  
Replaceable Nest  
Deep D.O.C.  
*page: GP 22*

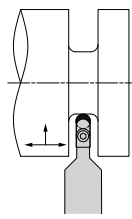

**CRDPN-VMS**  
Milled Nest  
Shallow D.O.C.  
*page: GP 23*

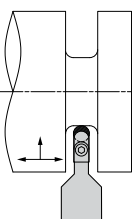

**CRDPN-VM**  
Milled Nest  
Deep D.O.C.  
*page: GP 23*

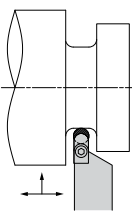

**O.D. G/P Toolholder**  
Replaceable Nest  
Shallow D.O.C.  
*page: GP 24*

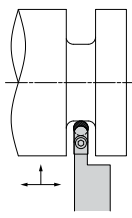

**O.D. G/P Toolholder**  
Replaceable Nest  
Deep D.O.C.  
*page: GP 24*

## V-Bottom Round Toolholders *continued*

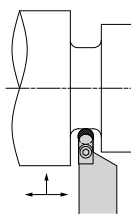

**O.D. G/P Toolholder**  
Milled Nest  
Shallow D.O.C.  
*page: GP 25*

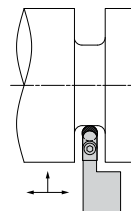

**O.D. G/P Toolholder**  
Milled Nest  
Deep D.O.C.  
*page: GP 25*

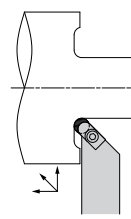

**CRGPR-V**  
**CRGPL-V**  
45°  
Replaceable Nest  
*page: GP 26*

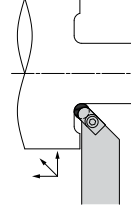

**CRGPR-VM**  
**CRGPL-VM**  
45°  
Milled Nest  
*page: GP 26*

## Single-Ended Groovers

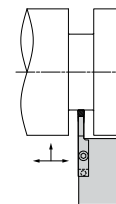

**Deep D.O.C.**  
*page: GP 27-28*

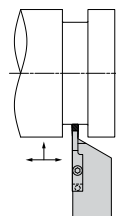

**Shallow D.O.C.**  
*page: GP 29-30*

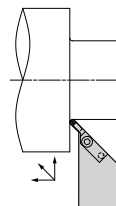

**45° G/P Toolholder**  
*page: GP 31*

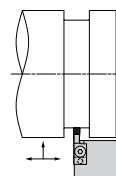

**90° G/P Toolholder**  
*page: GP 32-33*

GROOVING, PROFILING, and CUT-OFF

## Grooving, Profiling, and Cut-Off Bars

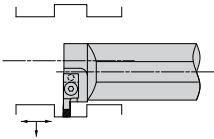

**Cut-Off  
Grooving Bar**  
*page: GP 34*

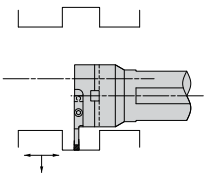

**Cut-Off  
Grooving  
Support Blade**  
For Single-Ended,  
V-Bottom Inserts  
*page: GP 35*

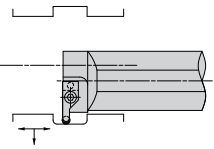

**Profiling Bar**  
Round V-Bottom Insert  
Milled Nest  
*page: GP 36*

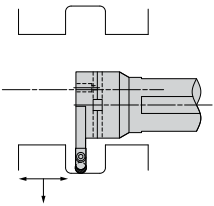

**Profiling Support  
Blade**  
Round V-Bottom Insert  
Milled Nest  
*page: GP 37*

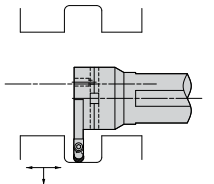

**Profiling Support  
Blade**  
Round V-Bottom Insert  
Replaceable Nest  
*page: GP 37*

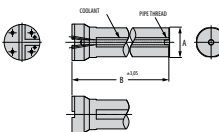

**Shank Options**  
For Bolt-On  
Support Blades  
*page: GP 38*

# CRDPN-VS Toolholder

Round V-Bottom Insert / Replaceable Nest / Shallow D.O.C. (D) Series

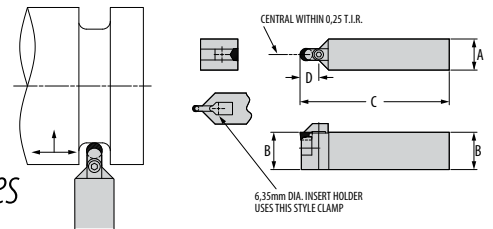

Part Number	Gage Inserts	D.O.C. D	Dimensions (mm)			Standard Components				*Tune-Up Kit Includes all Standard Components
			A	B	C	Nest	Nest Screw	Clamp	Clamp Screw	
CRDPN-2525-06VS	**RPGX-060400	10	25	25	150	410631	BHCS M2.5-0.45x10mm	411910-250VRC	434416	TK-02684
CRDPN-3232-06VS	**RPGX-060400	10	32	32	170	410631	BHCS M2.5-0.45x10mm	411910-250VRC	434416	TK-02684
CRDPN-4040-06VS	**RPGX-060400	10	40	40	200	410631	BHCS M2.5-0.45x10mm	411910-250VRC	434416	TK-02684
CRDPN-2525-09VS	**RPGX-090700	15	25	25	150	413970	TBHCS M3-0.5x12mm	308063	TSHCS M5-0.8x12mm	TK-0268
CRDPN-3232-09VS	**RPGX-090700	15	32	32	170	413970	TBHCS M3-0.5x12mm	308063	TSHCS M5-0.8x12mm	TK-02685
CRDPN-4040-09VS	**RPGX-090700	15	40	40	200	413970	TBHCS M3-0.5x12mm	308063	TSHCS M5-0.8x12mm	TK-02685
CRDPN-2525-12VS	**RPGX-120700	20	25	25	150	414007	TBHCS M5-0.8x16mm	308136	434258	TK-02686
CRDPN-3232-12VS	**RPGX-120700	20	32	32	170	414007	TBHCS M5-0.8x16mm	308136	434258	TK-02686
CRDPN-4040-12VS	**RPGX-120700	20	40	40	200	414007	TBHCS M5-0.8x16mm	308136	434258	TK-02686

NOTE: See page GP 14 for ceramic and carbide inserts.

\* Tune-Up Kits include one complete set of Standard Components to allow you to refurbish the toolholder.

\*\* RCGN can be used in place of RPGN.

# CRDPN-V Toolholder

Round V-Bottom Insert / Replaceable Nest / Deep D.O.C. (D) Series

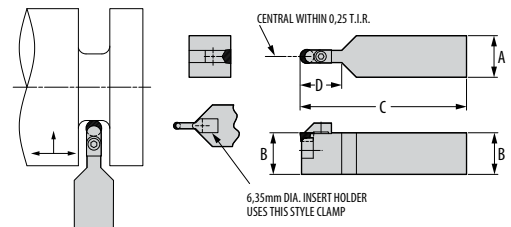

Part Number	Gage Inserts	D.O.C. D	Dimensions (mm)			Standard Components				*Tune-Up Kit Includes all Standard Components
			A	B	C	Nest	Nest Screw	Clamp	Clamp Screw	
CRDPN-2525-06V	**RPGX-060400	19	25	25	150	410631	BHCS M2.5-0.45x10mm	411910-250VRC	434416	TK-02684
CRDPN-3232-06V	**RPGX-060400	19	32	32	170	410631	BHCS M2.5-0.45x10mm	411910-250VRC	434416	TK-02684
CRDPN-4040-06V	**RPGX-060400	19	40	40	200	410631	BHCS M2.5-0.45x10mm	411910-250VRC	434416	TK-02684
CRDPN-2525-09V	**RPGX-090700	28	25	25	150	413970	TBHCS M3-0.5x12mm	308063	TSHCS M5-0.8x12mm	TK-02685
CRDPN-3232-09V	**RPGX-090700	28	32	32	170	413970	TBHCS M3-0.5x12mm	308063	TSHCS M5-0.8x12mm	TK-02685
CRDPN-4040-09V	**RPGX-090700	28	40	40	200	413970	TBHCS M3-0.5x12mm	308063	TSHCS M5-0.8x12mm	TK-02685
CRDPN-2525-12V	**RPGX-120700	38	25	25	150	414007	TBHCS M5-0.8x16mm	308136	434258	TK-02686
CRDPN-3232-12V	**RPGX-120700	38	32	32	170	414007	TBHCS M5-0.8x16mm	308136	434258	TK-02686
CRDPN-4040-12V	**RPGX-120700	38	40	40	200	414007	TBHCS M5-0.8x16mm	308136	434258	TK-02686

NOTE: See page GP 14 for ceramic and carbide inserts.

\* Tune-Up Kits include one complete set of Standard Components to allow you to refurbish the toolholder.

\*\* RCGN can be used in place of RPGN.

GROOVING, PROFILING, and CUT-OFF

# CRDPN-VMS Toolholder

Round V-Bottom Insert / Milled Nest / Shallow D.O.C. (D) Series

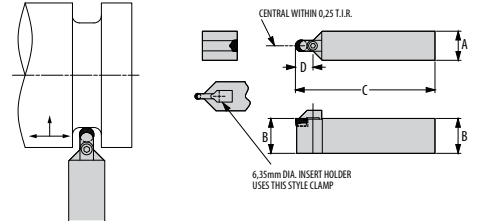

Part Number	Gage Inserts	D.O.C. D	Dimensions (mm)			Standard Components		*Tune-Up Kit Includes all Standard Components	Opt. Component Insert Screw
			A	B	C	Clamp	Clamp Screw		
CRDPN-2525-06VMS	**RPGX-060400	10	25	25	150	411910-250VRC	434416	TK-02717	PT-542T
CRDPN-3232-06VMS	**RPGX-060400	10	32	32	170	411910-250VRC	434416	TK-02717	PT-542T
CRDPN-4040-06VMS	**RPGX-060400	10	40	40	200	411910-250VRC	434416	TK-02717	PT-542T
CRDPN-2525-09VMS	**RPGX-090700	15	25	25	150	308063	TSHCS M5-0.8x12mm	TK-01709	PT-545T
CRDPN-3232-09VMS	**RPGX-090700	15	32	32	170	308063	TSHCS M5-0.8x12mm	TK-01709	PT-545T
CRDPN-4040-09VMS	**RPGX-090700	15	40	40	200	308063	TSHCS M5-0.8x12mm	TK-01709	PT-545T
CRDPN-2525-12VMS	**RPGX-120700	20	25	25	150	308136	434258	TK-02691	CO-5018
CRDPN-3232-12VMS	**RPGX-120700	20	32	32	170	308136	434258	TK-02691	CO-5018
CRDPN-4040-12VMS	**RPGX-120700	20	40	40	200	308136	434258	TK-02691	CO-5018

NOTE: See page GP 14 for ceramic and carbide inserts.

NOTE: Use carbide inserts RCGT and RPGT with optional insert screw for finishing.

\* Tune-Up Kits include one complete set of Standard Components to allow you to refurbish the toolholder.

\*\* RCGN can be used in place of RPGN.

# CRDPN-VM Toolholder

Round V-Bottom Insert / Milled Nest / Deep D.O.C. (D) Series

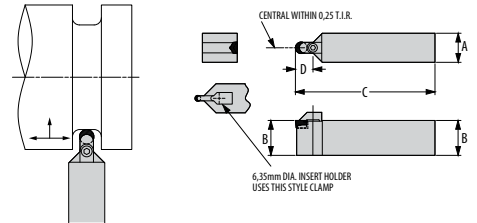

Part Number	Gage Inserts	D.O.C. D	Dimensions (mm)			Standard Components		*Tune-Up Kit Includes all Standard Components	Opt. Component Insert Screw
			A	B	C	Clamp	Clamp Screw		
CRDPN-2525-06VM	**RPGX-060400	19	25	25	150	411910-250VRC	434416	TK-02717	PT-542T
CRDPN-3232-06VM	**RPGX-060400	19	32	32	170	411910-250VRC	434416	TK-02717	PT-542T
CRDPN-4040-06VM	**RPGX-060400	19	40	40	200	411910-250VRC	434416	TK-02717	PT-542T
CRDPN-2525-09VM	**RPGX-090700	28	25	25	150	308063	TSHCS M5-0.8x12mm	TK-02734	PT-545T
CRDPN-3232-09VM	**RPGX-090700	28	32	32	170	308063	TSHCS M5-0.8x12mm	TK-02734	PT-545T
CRDPN-4040-09VM	**RPGX-090700	28	40	40	200	308063	TSHCS M5-0.8x12mm	TK-02734	PT-545T
CRDPN-2525-12VM	**RPGX-120700	38	25	25	150	308136	434258	TK-02691	CO-5018
CRDPN-3232-12VM	**RPGX-120700	38	32	32	170	308136	434258	TK-02691	CO-5018
CRDPN-4040-12VM	**RPGX-120700	38	40	40	200	308136	434258	TK-02691	CO-5018

NOTE: See page GP 14 for ceramic and carbide inserts.

NOTE: Use carbide inserts RCGT and RPGT with optional insert screw for finishing.

\* Tune-Up Kits include one complete set of Standard Components to allow you to refurbish the toolholder.

\*\* RCGN can be used in place of RPGN.

GROOVING, PROFILING, and CUT-OFF

# O.D. Grooving/Profiling Toolholder

Round V-Bottom Insert / Replaceable Nest / Shallow D.O.C. (D) Series

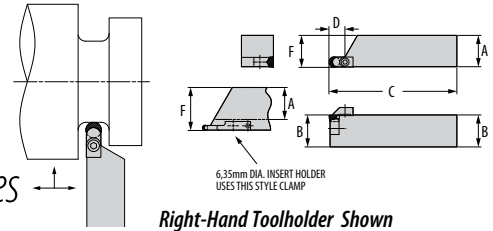

Right-Hand Toolholder Shown

Part Number		Gage Inserts	D.O.C. D	Dimensions (mm)				Standard Components				*Tune-Up Kit Includes all Standard Components
Right	Left			A†	B	C	F	Nest	Nest Screw	Clamp	Clamp Screw	
M-415419-06VRS	-	**RPGX-060400	10	37	25	150	38	410631	BHCS M2.5-0.45x10mm	411905-250VRC	434259	TK-02692
-	M-415420-06VRS	**RPGX-060400	10	37	25	150	38	410631	BHCS M2.5-0.45x10mm	411906-250VRC	434259	TK-02693
M-415421-06VRS	-	**RPGX-060400	10	44	32	170	45	410631	BHCS M2.5-0.45x10mm	411905-250VRC	434259	TK-02692
-	M-415422-06VRS	**RPGX-060400	10	44	32	170	45	410631	BHCS M2.5-0.45x10mm	411906-250VRC	434259	TK-02693
M-415423-06VRS	-	**RPGX-060400	10	52	40	200	53	410631	BHCS M2.5-0.45x10mm	411905-250VRC	434259	TK-02692
-	M-415424-06VRS	**RPGX-060400	10	52	40	200	53	410631	BHCS M2.5-0.45x10mm	411906-250VRC	434259	TK-02693
M-415427-09VRS	M-415428-09VRS	**RPGX-090700	15	24	25	150	25	413970	TBHCS M3-0.5x12mm	308063	TSHCS M5-0.8x12mm	TK-02685
M-415429-09VRS	M-415430-09VRS	**RPGX-090700	15	31	32	170	32	413970	TBHCS M3-0.5x12mm	308063	TSHCS M5-0.8x12mm	TK-02685
M-415431-09VRS	M-415432-09VRS	**RPGX-090700	15	39	40	200	40	413970	TBHCS M3-0.5x12mm	308063	TSHCS M5-0.8x12mm	TK-02685
M-415435-12VRS	M-415436-12VRS	**RPGX-120700	20	24	25	150	25	414007	TBHCS M5-0.8x16mm	308136	434258	TK-02696
M-415437-12VRS	M-415438-12VRS	**RPGX-120700	20	31	32	170	32	414007	TBHCS M5-0.8x16mm	308136	434258	TK-02696
M-415439-12VRS	M-415440-12VRS	**RPGX-120700	20	40	40	200	40	414007	TBHCS M5-0.8x16mm	308136	434258	TK-02696

NOTE: See page GP 14 for ceramic and carbide inserts.

† "A" indicates width of shank available for clamping, (not necessarily overall shank width).

\* Tune-Up Kits include one complete set of Standard Components to allow you to refurbish the toolholder.

\*\* RCGN can be used in place of RPGN.

# O.D. Grooving/Profiling Toolholder

Round V-Bottom Insert / Replaceable Nest / Deep D.O.C. (D) Series

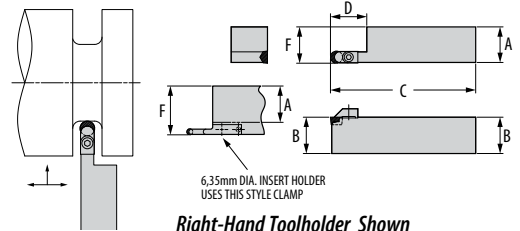

Right-Hand Toolholder Shown

Part Number		Gage Inserts	D.O.C. D	Dimensions (mm)				Standard Components				*Tune-Up Kit Includes all Standard Components
Right	Left			A†	B	C	F	Nest	Nest Screw	Clamp	Clamp Screw	
M-411149-06VRS	-	**RPGX-060400	19	37	25	150	38	410631	BHCS M2.5-0.45x10mm	411905-250VRC	434259	TK-02692
-	411150-06VRS	**RPGX-060400	19	37	25	150	38	410631	BHCS M2.5-0.45x10mm	411906-250VRC	434259	TK-02693
M-411151-06VRS	-	**RPGX-060400	19	44	32	170	45	410631	BHCS M2.5-0.45x10mm	411905-250VRC	434259	TK-02692
-	M-411956-06VRS	**RPGX-060400	19	44	32	170	45	410631	BHCS M2.5-0.45x10mm	411906-250VRC	434259	TK-02693
M-411957-06VRS	-	**RPGX-060400	19	52	40	200	53	410631	BHCS M2.5-0.45x10mm	411905-250VRC	434259	TK-02692
-	M-411958-06VRS	**RPGX-060400	19	52	40	200	53	410631	BHCS M2.5-0.45x10mm	411906-250VRC	434259	TK-02693
M-411157-09VRS	M-411158-09VRS	**RPGX-090700	29	24	25	150	25	413970	TBHCS M3-0.5x12mm	308063	TSHCS M5-0.8x12mm	TK-02685
M-411159-09VRS	M-411160-09VRS	**RPGX-090700	29	31	32	170	32	413970	TBHCS M3-0.5x12mm	308063	TSHCS M5-0.8x12mm	TK-02685
M-411161-09VRS	M-411162-09VRS	**RPGX-090700	29	39	40	200	40	413970	TBHCS M3-0.5x12mm	308063	TSHCS M5-0.8x12mm	TK-02685
M-411165-12VRS	M-411166-12VRS	**RPGX-120700	38	24	25	150	25	414007	TBHCS M5-0.8x16mm	308136	434258	TK-02686
M-411167-12VRS	M-411168-12VRS	**RPGX-120700	38	31	32	170	32	414007	TBHCS M5-0.8x16mm	308136	434258	TK-02686
M-411169-12VRS	M-411170-12VRS	**RPGX-120700	38	39	40	200	40	414007	TBHCS M5-0.8x16mm	308136	434258	TK-02686

NOTE: See page GP 14 for ceramic and carbide inserts.

† "A" indicates width of shank available for clamping, (not necessarily overall shank width).

\* Tune-Up Kits include one complete set of Standard Components to allow you to refurbish the toolholder.

\*\* RCGN can be used in place of RPGN.



GROOVING, PROFILING, and CUT-OFF

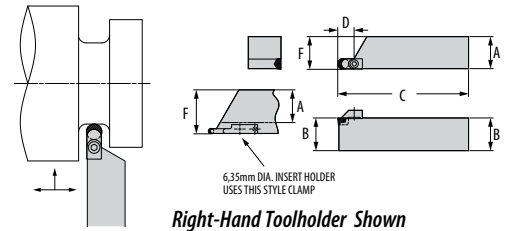

# O.D. Grooving/Profiling Toolholder

## Round V-Bottom Insert / Milled Nest / Shallow D.O.C. (D) Series

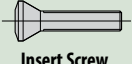
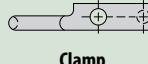

Part Number		Gage 	D.O.C.	Dimensions (mm)					Standard Components		*Tune-Up Kit Includes all Standard Components	Opt. Component 
Right	Left			D	A†	B	C	F				
M-421450-06VMRS	—	**RPGX-060400	10	37	25	150	38	411905-250VRC	434259	TK-02689	PT-542T	
—	M-421451-06VMRS	**RPGX-060400	10	37	25	150	38	411906-250VRC	434259	TK-02690	PT-542T	
M-421452-06VMRS	—	**RPGX-060400	10	44	32	170	45	411905-250VRC	434259	TK-02689	PT-542T	
—	M-421453-06VMRS	**RPGX-060400	10	44	32	170	45	411906-250VRC	434259	TK-02690	PT-542T	
M-421454-06VMRS	—	**RPGX-060400	10	52	40	200	53	411905-250VRC	434259	TK-02689	PT-542T	
—	M-421455-06VMRS	**RPGX-060400	10	52	40	200	53	411906-250VRC	434259	TK-02690	PT-542T	
M-421458-09VMRS	M-421459-09VMRS	**RPGX-090700	15	24	25	150	25	308063	TSHCS M5-0.8x12mm	TK-02734	PT-545T	
M-421460-09VMRS	M-421461-09VMRS	**RPGX-090700	15	31	32	170	32	308063	TSHCS M5-0.8x12mm	TK-02734	PT-545T	
M-421462-09VMRS	M-421463-09VMRS	**RPGX-090700	15	39	40	200	40	308063	TSHCS M5-0.8x12mm	TK-02734	PT-545T	
M-421466-12VMRS	M-421467-12VMRS	**RPGX-120700	20	24	25	150	25	308136	434258	TK-02691	CO-5018	
M-421468-12VMRS	M-421469-12VMRS	**RPGX-120700	20	31	32	170	32	308136	434258	TK-02691	CO-5018	
M-421470-12VMRS	M-421471-12VMRS	**RPGX-120700	20	39	40	200	40	308136	434258	TK-02691	CO-5018	

NOTE: See page GP 14 for ceramic and carbide inserts.

NOTE: Use carbide inserts RCGT and RPGT with optional insert screw for finishing.

† "A" indicates width of shank available for clamping, (not necessarily overall shank width).



\* Tune-Up Kits include one complete set of Standard Components to allow you to refurbish the toolholder.

\*\* RCGN can be used in place of RPGN.

# O.D. Grooving/Profiling Toolholder

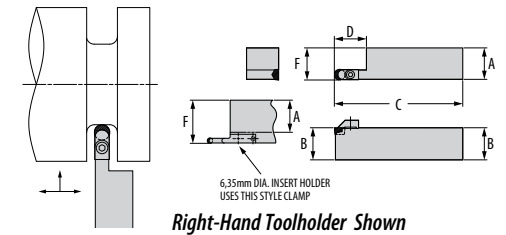
## Round V-Bottom Insert / Milled Nest / Deep D.O.C. (D) Series

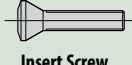
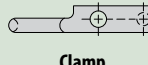

Part Number		Gage 	D.O.C.	Dimensions (mm)					Standard Components		*Tune-Up Kit Includes all Standard Components	Opt. Component 
Right	Left			D	A†	B	C	F				
M-421498-06VMRS	—	**RPGX-060400	19	37	25	150	38	411905-250VRC	434259	TK-02689	PT-542T	
—	M-421499-06VMRS	**RPGX-060400	19	37	25	150	38	411906-250VRC	434259	TK-02690	PT-542T	
M-421500-06VMRS	—	**RPGX-060400	19	44	32	170	45	411905-250VRC	434259	TK-02689	PT-542T	
—	M-421501-06VMRS	**RPGX-060400	19	44	32	170	45	411906-250VRC	434259	TK-02690	PT-542T	
M-421502-06VMRS	—	**RPGX-060400	19	52	40	200	53	411905-250VRC	434259	TK-02689	PT-542T	
—	M-421503-06VMRS	**RPGX-060400	19	52	40	200	53	411906-250VRC	434259	TK-02690	PT-542T	
M-421504-09VMRS	M-421505-09VMRS	**RPGX-090700	29	24	25	150	25	308063	TSHCS M5-0.8x12mm	TK-02734	PT-545T	
M-421506-09VMRS	M-421507-09VMRS	**RPGX-090700	29	331	32	170	32	308063	TSHCS M5-0.8x12mm	TK-02734	PT-545T	
M-421508-09VMRS	M-421509-09VMRS	**RPGX-090700	29	39	40	200	40	308063	TSHCS M5-0.8x12mm	TK-02734	PT-545T	
M-421510-12VMRS	M-421511-12VMRS	**RPGX-120700	38	24	25	150	25	308136	434258	TK-02691	CO-5018	
M-421512-12VMRS	M-421513-12VMRS	**RPGX-120700	38	31	32	170	32	308136	434258	TK-02691	CO-5018	
M-421514-12VMRS	M-421515-12VMRS	**RPGX-120700	38	39	40	200	40	308136	434258	TK-02691	CO-5018	

NOTE: See page GP 14 for ceramic and carbide inserts.

NOTE: Use carbide inserts RCGT and RPGT with optional insert screw for finishing.

† "A" indicates width of shank available for clamping, (not necessarily overall shank width).

\* Tune-Up Kits include one complete set of Standard Components to allow you to refurbish the toolholder.

\*\* RCGN can be used in place of RPGN.

# CRGPR-V/CRGPL-V

45° Grooving/Profiling Toolholder  
Round V-Bottom Insert; Replaceable Nest

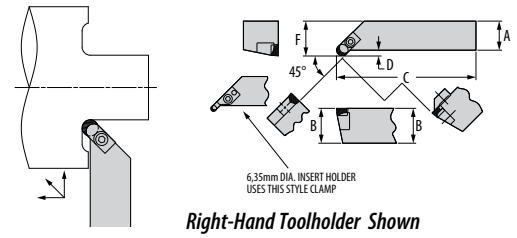

Part Number		Gage Inserts	D.O.C.	Dimensions (mm)					Standard Components				*Tune-Up Kit Includes all Standard Components
Right	Left			D	A†	B	C	F	Nest	Nest Screw	Clamp	Clamp Screw	
CRGPR-2525-06V	—	**RPGX-060400	7	25	25	150	32	411108	BHCS M2.5-0.45x10mm	412131-250GC	434258	TK-02687	
—	CRGPL-2525-06V	**RPGX-060400	7	25	25	150	32	411108	BHCS M2.5-0.45x10mm	412132-250GC	434258	TK-02731	
CRGPR-3232-06V	—	**RPGX-060400	7	32	32	170	39	411108	BHCS M2.5-0.45x10mm	412131-250GC	434258	TK-02687	
—	CRGPL-3232-06V	**RPGX-060400	7	32	32	170	39	411108	BHCS M2.5-0.45x10mm	412132-250GC	434258	TK-02731	
CRGPR-4040-06V	—	**RPGX-060400	7	40	40	200	47	411108	BHCS M2.5-0.45x10mm	412131-250GC	434258	TK-02687	
—	CRGPL-4040-06V	**RPGX-060400	7	40	40	200	47	411108	BHCS M2.5-0.45x10mm	412132-250GC	434258	TK-02731	
CRGPR-2525-09V	CRGPL-2525-09V	**RPGX-090700	7	25	25	150	32	414009	TBHCs M3-0.5x12mm	308063	TSHCS M5-0.8x12mm	TK-02733	
CRGPR-3232-09V	CRGPL-3232-09V	**RPGX-090700	7	32	32	170	39	414009	TBHCs M3-0.5x12mm	308063	TSHCS M5-0.8x12mm	TK-02733	
CRGPR-4040-09V	CRGPL-4040-09V	**RPGX-090700	7	40	40	200	47	414009	TBHCs M3-0.5x12mm	308063	TSHCS M5-0.8x12mm	TK-02733	
CRGPR-2525-12V	CRGPL-2525-12V	**RPGX-120700	7	25	25	150	32	414008	TBHCs M5-0.8x16mm	308136	434258	TK-02732	
CRGPR-3232-12V	CRGPL-3232-12V	**RPGX-120700	7	32	32	170	39	414008	TBHCs M5-0.8x16mm	308136	434258	TK-02732	
CRGPR-4040-12V	CRGPL-4040-12V	**RPGX-120700	7	40	40	200	47	414008	TBHCs M5-0.8x16mm	308136	434258	TK-02732	

NOTE: See page GP 14 for ceramic and carbide inserts.

† "A" indicates width of shank available for clamping, (not necessarily overall shank width).

\* Tune-Up Kits include one complete set of Standard Components to allow you to refurbish the toolholder.

\*\* RCGN can be used in place of RPGN.

# CRGPR-VM/CRGPL-VM

45° Grooving/Profiling Toolholder  
Round V-Bottom Insert; Milled Nest

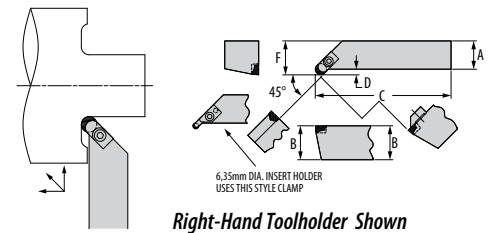

Part Number		Gage Inserts	D.O.C.	Dimensions (mm)					Standard Components		*Tune-Up Kit Includes all Standard Components	Optional Component Insert Screw
Right	Left			D	A†	B	C	F	Clamp	Clamp Screw		
CRGPR-2525-06VM	—	**RPGX-060400	7	25	25	150	32	412131-250GC	434259	TK-02745	PT-542T	
—	CRGPL-2525-06VM	**RPGX-060400	7	25	25	150	32	412132-250GC	434258	TK-02746	PT-542T	
CRGPR-3232-06VM	—	**RPGX-060400	7	32	32	170	39	412131-250GC	434259	TK-02745	PT-542T	
—	CRGPL-3232-06VM	**RPGX-060400	7	32	32	170	39	412132-250GC	434258	TK-02746	PT-542T	
CRGPR-4040-06VM	—	**RPGX-060400	7	40	40	200	47	412131-250GC	434259	TK-02745	PT-542T	
—	CRGPL-4040-06VM	**RPGX-060400	7	40	40	200	47	412132-250GC	434258	TK-02746	PT-542T	
CRGPR-2525-09VM	CRGPL-2525-09VM	**RPGX-090700	7	25	25	150	32	308063	TSHCS M5-0.8x12mm	TK-02733	PT-545T	
CRGPR-3232-09VM	CRGPL-3232-09VM	**RPGX-090700	7	32	32	170	39	308063	TSHCS M5-0.8x12mm	TK-02733	PT-545T	
CRGPR-4040-09VM	CRGPL-4040-09VM	**RPGX-090700	7	40	40	200	47	308063	TSHCS M5-0.8x12mm	TK-02733	PT-545T	
CRGPR-2525-12VM	CRGPL-2525-12VM	**RPGX-120700	7	25	25	150	32	308136	434258	TK-02691	CO-5018	
CRGPR-3232-12VM	CRGPL-3232-12VM	**RPGX-120700	7	32	32	170	39	308136	434258	TK-02691	CO-5018	
CRGPR-4040-12VM	CRGPL-4040-12VM	**RPGX-120700	7	40	40	200	47	308136	434258	TK-02691	CO-5018	

NOTE: See page GP 14 for ceramic and carbide inserts.

NOTE: Use carbide inserts RCGT and RPGT with optional insert screw for finishing.

† "A" indicates width of shank available for clamping, (not necessarily overall shank width).

\* Tune-Up Kits include one complete set of Standard Components to allow you to refurbish the toolholder.

\*\* RCGN can be used in place of RPGN.

# Grooving/Profiling/Cut-Off Toolholder

Deep D.O.C. Series

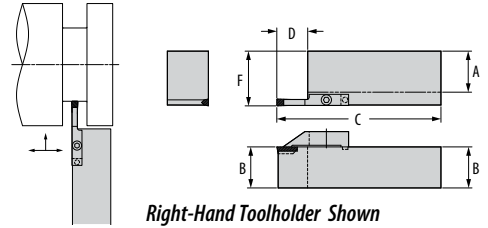

Part Number		Groove Width	D.O.C.	Dimensions (mm)				Standard Components		*Tune-Up Kit	Optional Components	
Right	Left		D	A†	B	C	F	Insert	Clamp	Includes all Standard Components	Insert	Clamp
M-427635-094VGS	—	2,39	19	25	25	150	38	WGC-4094	427651-094GC	TK-02626	COS-4094-0	429524-094GC
—	M-427636-094VGS	2,39	19	25	25	150	38		427652-094GC	TK-02627		429525-094GC
M-427637-094VGS	—	2,39	19	32	32	170	45	WG-4094	427651-094GC	TK-02626	COS-4094-4L	429524-094GC
—	M-427638-094VGS	2,39	19	32	32	170	45		427652-094GC	TK-02627		429525-094GC
M-427639-094VGS	—	2,39	19	40	40	200	53	—	427651-094GC	TK-02626	COS-4094-4R	429524-094GC
—	M-427640-094VGS	2,39	19	40	40	200	53		427652-094GC	TK-02627		429525-094GC
M-411173-125VGS	—	3,18	19	25	25	150	38	WGC-4125	411966-125GC	TK-02628	GTS-4125	429512-125GC
—	M-411961-125VGS	3,18	19	25	25	150	38		411967-125GC	TK-02629		429513-125GC
M-411250-125VGS	—	3,18	19	32	32	170	45	WG-4125	411966-125GC	TK-02628	COS-4125-0	429512-125GC
—	M-411251-125VGS	3,18	19	32	32	170	45		GTS-4125-1	411967-125GC		TK-02629
M-411962-125VGS	—	3,18	19	40	40	200	53	GTS-4125-2	411966-125GC	TK-02628	COS-4125-4R	429512-125GC
—	M-411963-125VGS	3,18	19	40	40	200	53		411967-125GC	TK-02629		429513-125GC
M-411964-156VGS	—	3,96	19	25	25	150	38	WGC-4156	411968-156GC	TK-02630	—	436373-156GC
—	M-411965-156VGS	3,96	19	25	25	150	38		411969-156GC	TK-02631		436374-156GC
M-411256-156VGS	—	3,96	19	32	32	170	45	WG-4156	411968-156GC	TK-02630	GTS-4156	436373-156GC
—	M-411257-156VGS	3,96	19	32	32	170	45		411969-156GC	TK-02631		436374-156GC
M-411258-156VGS	—	3,96	19	40	40	200	53	—	411968-156GC	TK-02630	—	436373-156GC
—	M-411259-156VGS	3,96	19	40	40	200	53		411969-156GC	TK-02631		436374-156GC
M-411970-187VGS	—	4,75	19	25	25	150	38	WGC-4187	411977-187GC	TK-02632	GTS-4187	429518-187GC
—	M-411178-187VGS	4,75	19	25	25	150	38		411978-187GC	TK-02633		429519-187GC
M-411262-187VGS	—	4,75	19	32	32	170	45	WG-4187	411977-187GC	TK-02632	COS-4187-0	429518-187GC
—	M-411263-187VGS	4,75	19	32	32	170	45		GTS-4187-1	411978-187GC		TK-02633
M-411971-187VGS	—	4,75	19	40	40	200	53	GTS-4187-2	411977-187GC	TK-02632	COS-4187-4L	429518-187GC
—	M-411972-187VGS	4,75	19	40	40	200	53		411978-187GC	TK-02633		429519-187GC
M-411179-218VGS	—	5,54	29	25	25	150	38	WGC-6218	411979-218GC	TK-02634	—	—
—	M-411180-218VGS	5,54	29	25	25	150	38		411130-218GC	TK-02635		—
M-411268-218VGS	—	5,54	29	32	32	170	45	WG-6218	411979-218GC	TK-02634	—	—
—	M-411269-218VGS	5,54	29	32	32	170	45		411130-218GC	TK-02635		—
M-411270-218VGS	—	5,54	29	40	40	200	53	—	411979-218GC	TK-02634	—	—
—	M-411271-218VGS	5,54	29	40	40	200	53		411130-218GC	TK-02635		—

† "A" indicates width of shank available for clamping, (not necessarily overall shank width).

\* All toolholders include standard clamp and 1/4-20 x 1 SHCS.

GTS is Greenleaf's groove/turn system insert with chip control. Page GP 09.

COS is Greenleaf's cut-off system insert. Page GP 08.

WG is Greenleaf flat-top groover with an 11° nose clearance. Pages GP 10 and GP 11.

WGC is Greenleaf's flat-top groover with a 6° nose clearance. Pages GP 12 and GP 13.

Continued on next page.

GROOVING, PROFILING, and CUT-OFF

# Grooving/Profiling/Cut-Off Toolholder

Deep D.O.C. Series (Continued)

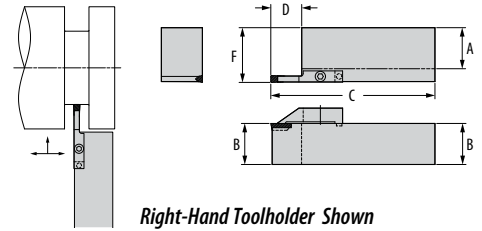

Part Number		Groove Width	D.O.C. D	Dimensions (mm)				Standard Components		*Tune-Up Kit Includes all Standard Components	Optional Components	
Right	Left			A†	B	C	F	Insert	Clamp		Insert	Clamp
M-411973-250VGS	–	6,35	29	25	25	150	38	WGC-6250	411980-250GC	TK-02636	–	–
–	M-411974-250VGS	6,35	29	25	25	150	38	WG-6250	411981-250GC	TK-02637	–	–
M-411975-250VGS	–	6,35	29	32	32	170	45	GTS-6250	411980-250GC	TK-02636	–	–
–	M-411275-250VGS	6,35	29	32	32	170	45		411981-250GC	TK-02637	–	–
M-411276-250VGS	–	6,35	29	40	40	200	53	GTS-6250-1	411980-250GC	TK-02636	–	–
–	M-411277-250VGS	6,35	29	40	40	200	53	GTS-6250-2	411981-250GC	TK-02637	–	–
M-411183-281VGS	–	7,14	29	25	25	150	38	WGC-6281	411133-281GC	TK-02638	–	–
–	M-411184-281VGS	7,14	29	25	25	150	38		411134-281GC	TK-02648	–	–
M-411280-281VGS	–	7,14	29	32	32	170	45	WG-6281	411133-281GC	TK-02638	–	–
–	M-411281-281VGS	7,14	29	32	32	170	45		411134-281GC	TK-02648	–	–
M-411282-281VGS	–	7,14	29	40	40	200	53		411133-281GC	TK-02638	–	–
–	M-411283-281VGS	7,14	29	40	40	200	53		411134-281GC	TK-02648	–	–
M-411982-312VGS	–	7,92	38	25	25	150	38	WGC-8312	411985-312GC	TK-02640	–	–
–	M-411186-312VGS	7,92	38	25	25	150	38		411136-312GC	TK-02641	–	–
M-411286-312VGS	–	7,92	38	32	32	170	45	WG-8312	411985-312GC	TK-02640	–	–
–	M-411287-312VGS	7,92	38	32	32	170	45		411136-312GC	TK-02641	–	–
M-411288-312VGS	–	7,92	38	40	40	200	53		411985-312GC	TK-02640	–	–
–	M-411289-312VGS	7,92	38	40	40	200	53		411136-312GC	TK-02641	–	–
M-411187-344VGS	–	8,74	38	25	25	150	38	WGC-8344	411137-344GC	TK-02642	–	–
–	M-411188-344VGS	8,74	38	25	25	150	38		411138-344GC	TK-02643	–	–
M-411292-344VGS	–	8,74	38	32	32	170	45	WG-8344	411137-344GC	TK-02642	–	–
–	M-411293-344VGS	8,74	38	32	32	170	45		411138-344GC	TK-02643	–	–
M-411294-344VGS	–	8,74	38	40	40	200	53		411137-344GC	TK-02642	–	–
–	M-411295-344VGS	8,74	38	40	40	200	53		411138-344GC	TK-02643	–	–
M-411189-375VGS	–	9,53	38	25	25	150	38	WGC-8375	411986-375GC	TK-02649	–	–
–	M-411190-375VGS	9,53	38	25	25	150	38		411987-375GC	TK-02645	–	–
M-411983-375VGS	–	9,53	38	32	32	170	45	WG-8375	411986-375GC	TK-02649	–	–
–	M-411984-375VGS	9,53	38	32	32	170	45		411987-375GC	TK-02645	–	–
M-411300-375VGS	–	9,53	38	40	40	200	53		411986-375GC	TK-02649	–	–
–	M-411301-375VGS	9,53	38	40	40	200	53		411987-375GC	TK-02645	–	–

† "A" indicates width of shank available for clamping, (not necessarily overall shank width).

\* All toolholders include standard clamp and 1/4-20 x 1 SHCS.

GTS is Greenleaf's groove/turn system insert with chip control. Page GP 09.

COS is Greenleaf's cut-off system insert. Page GP 08.

WG is Greenleaf flat-top groover with an 11° nose clearance. Pages GP 10 and GP 11.

WGC is Greenleaf's flat-top groover with a 6° nose clearance. Pages GP 12 and GP 13.

# Grooving/Profiling/Cut-Off Toolholder

## Shallow D.O.C. Series

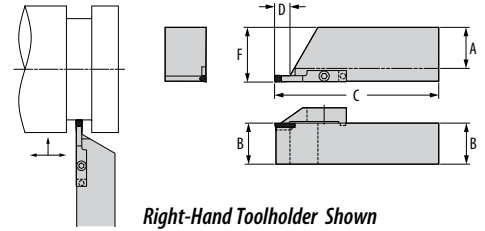

Part Number		Groove Width	D.O.C. D	Dimensions (mm)				Standard Components		*Tune-Up Kit Includes all Standard Components	Optional Components		
Right	Left			A†	B	C	F	Insert	Clamp		Insert	Clamp	
M-427641-094VGS	—	2,39	10	25	25	150	38	WG-4094	427651-094GC	TK-02626	COS-4094-0	429524-094GC	
—	M-427642-094VGS	2,39	10	25	25	150	38		427652-094GC	TK-02627		429525-094GC	
M-427643-094VGS	—	2,39	10	32	32	170	45		427651-094GC	TK-02626		429524-094GC	
—	M-427644-094VGS	2,39	10	32	32	170	45		427652-094GC	TK-02627		429525-094GC	
M-427645-094VGS	—	2,39	10	40	40	200	53		427651-094GC	TK-02626		COS-4094-4R	429524-094GC
—	M-427646-094VGS	2,39	10	40	40	200	53		427652-094GC	TK-02627		429525-094GC	
M-415316-125VGS	—	3,18	10	25	25	150	38	GTS-4125-1	411966-125GC	TK-02628	GTS-4125	429512-125GC	
—	M-415317-125VGS	3,18	10	25	25	150	38		411967-125GC	TK-02629		429513-125GC	
M-415318-125VGS	—	3,18	10	32	32	170	45	GTS-4125-2	411966-125GC	TK-02628	COS-4125-0	429512-125GC	
—	M-415319-125VGS	3,18	10	32	32	170	45		411967-125GC	TK-02629		429513-125GC	
M-415320-125VGS	—	3,18	10	40	40	200	53	WGC-4125	411966-125GC	TK-02628	COS-4125-4R	429512-125GC	
—	M-415321-125VGS	3,18	10	40	40	200	53		411967-125GC	TK-02629		429513-125GC	
M-415324-156VGS	—	3,96	10	25	25	150	38	WG-4156	411968-156GC	TK-02630	GTS-4156	436373-156GC	
—	M-415325-156VGS	3,96	10	25	25	150	38		411969-156GC	TK-02631		436374-156GC	
M-415326-156VGS	—	3,96	10	32	32	170	45	WGC-4156	411968-156GC	TK-02630		436373-156GC	
—	M-415327-156VGS	3,96	10	32	32	170	45		411969-156GC	TK-02631		436374-156GC	
M-415328-156VGS	—	3,96	10	40	40	200	53		411968-156GC	TK-02630		436373-156GC	
—	M-415329-156VGS	3,96	10	40	40	200	53		411969-156GC	TK-02631		436374-156GC	
M-415332-187VGS	—	4,75	10	25	25	150	38	GTS-4187-1	411977-187GC	TK-02632	GTS-4187	429518-187GC	
—	M-415333-187VGS	4,75	10	25	25	150	38		411978-187GC	TK-02633		429519-187GC	
M-415334-187VGS	—	4,75	10	32	32	170	45	GTS-4187-2	411977-187GC	TK-02632	COS-4187-0	429518-187GC	
—	M-415335-187VGS	4,75	10	32	32	170	45		411978-187GC	TK-02633		429519-187GC	
M-415336-187VGS	—	4,75	10	40	40	200	53	WGC-4187	411977-187GC	TK-02632	COS-4187-4R	429518-187GC	
—	M-415337-187VGS	4,75	10	40	40	200	53		411978-187GC	TK-02633		429519-187GC	
M-415340-218VGS	—	5,54	15	25	25	150	38	WG-6218	411979-218GC	TK-02634	—	—	
—	M-415341-218VGS	5,54	15	25	25	150	38		411130-218GC	TK-02635		—	
M-415342-218VGS	—	5,54	15	32	32	170	45	WGC-6218	411979-218GC	TK-02634		—	
—	M-415343-218VGS	5,54	15	32	32	170	45		411130-218GC	TK-02635		—	
M-415344-218VGS	—	5,54	15	40	40	200	53		411979-218GC	TK-02634		—	
—	M-415345-218VGS	5,54	15	40	40	200	53		411130-218GC	TK-02635		—	

† "A" indicates width of shank available for clamping, (not necessarily overall shank width).

\* All toolholders include standard clamp and 1/4-20 x 1 SHCS.

GTS is Greenleaf's groove/turn system insert with chip control. Page GP 09.

COS is Greenleaf's cut-off system insert. Page GP 08.

WG is Greenleaf flat-top groover with an 11° nose clearance. Pages GP 10 and GP 11.

WGC is Greenleaf's flat-top groover with a 6° nose clearance. Pages GP 12 and GP 13.

Continued on next page.

# Grooving/Profiling/Cut-Off Toolholder

Shallow D.O.C. Series (Continued)

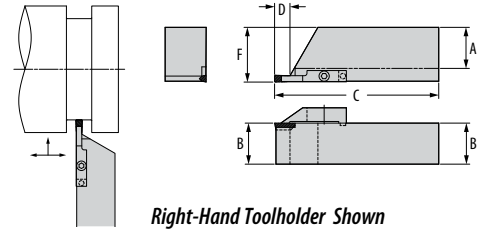

Part Number		Groove Width	D.O.C. D	Dimensions (mm)				Standard Components		*Tune-Up Kit Includes all Standard Components	Optional Components	
Right	Left			A†	B	C	F	Insert	Clamp		Insert	Clamp
M-415348-250VGS	–	6,35	15	25	25	150	38	GTS-6250	411980-250GC	TK-02636	–	–
–	M-415349-250VGS	6,35	15	25	25	150	38		411981-250GC	TK-02637	–	–
M-415350-250VGS	–	6,35	15	32	32	170	45	GTS-6250-1	411980-250GC	TK-02636	–	–
–	M-415351-250VGS	6,35	15	32	32	170	45	GTS-6250-2	411981-250GC	TK-02637	–	–
M-415352-250VGS	–	6,35	15	40	40	200	53	WG-6250	411980-250GC	TK-02636	–	–
–	M-415353-250VGS	6,35	15	40	40	200	53	WGC-6250	411981-250GC	TK-02637	–	–
M-415356-281VGS	–	7,14	15	25	25	150	38	WG-6281	411133-281GC	TK-02638	–	–
–	M-415357-281VGS	7,14	15	25	25	150	38		411134-281GC	TK-02648	–	–
M-415358-281VGS	–	7,14	15	32	32	170	45	WGC-6281	411133-281GC	TK-02638	–	–
–	M-415359-281VGS	7,14	15	32	32	170	45		411134-281GC	TK-02648	–	–
M-415360-281VGS	–	7,14	15	40	40	200	53		411133-281GC	TK-02638	–	–
–	M-415361-281VGS	7,14	15	40	40	200	53		411134-281GC	TK-02648	–	–
M-415364-312VGS	–	7,92	20	25	25	150	38	WG-8312	411985-312GC	TK-02640	–	–
–	M-415365-312VGS	7,92	20	25	25	150	38		411136-312GC	TK-02641	–	–
M-415366-312VGS	–	7,92	20	32	32	170	45	WGC-8312	411985-312GC	TK-02640	–	–
–	M-415367-312VGS	7,92	20	32	32	170	45		411136-312GC	TK-02641	–	–
M-415368-312VGS	–	7,92	20	40	40	200	53		411985-312GC	TK-02640	–	–
–	M-415369-312VGS	7,92	20	40	40	200	53		411136-312GC	TK-02641	–	–
M-415372-344VGS	–	8,74	20	25	25	150	38	WG-8344	411137-344GC	TK-02642	–	–
–	M-415373-344VGS	8,74	20	25	25	150	38		411138-344GC	TK-02643	–	–
M-415374-344VGS	–	8,74	20	32	32	170	45	WGC-8344	411137-344GC	TK-02642	–	–
–	M-415375-344VGS	8,74	20	32	32	170	45		411138-344GC	TK-02643	–	–
M-415376-344VGS	–	8,74	20	40	40	200	53		411137-344GC	TK-02642	–	–
–	M-415377-344VGS	8,74	20	40	40	200	53		411138-344GC	TK-02643	–	–
M-415380-375VGS	–	9,53	20	25	25	150	38	WG-8375	411986-375GC	TK-02649	–	–
–	M-415381-375VGS	9,53	20	25	25	150	38		411987-375GC	TK-02645	–	–
M-415382-375VGS	–	9,53	20	32	32	170	45		411986-375GC	TK-02649	–	–
–	M-415383-375VGS	9,53	20	32	32	170	45		411987-375GC	TK-02645	–	–
M-415384-375VGS	–	9,53	20	40	40	200	53		411986-375GC	TK-02649	–	–
–	M-415385-375VGS	9,53	20	40	40	200	53		411987-375GC	TK-02645	–	–

† "A" indicates width of shank available for clamping, (not necessarily overall shank width).

\* All toolholders include standard clamp and 1/4-20 x 1 SHCS.

GTS is Greenleaf's groove/turn system insert with chip control. Page GP 09.

COS is Greenleaf's cut-off system insert. Page GP 08.



WG is Greenleaf flat-top groover with an 11° nose clearance. Pages GP 10 and GP 11.

WGC is Greenleaf's flat-top groover with a 6° nose clearance. Pages GP 12 and GP 13.

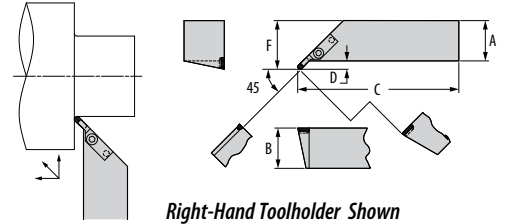
# 45° Grooving/Profiling Toolholder

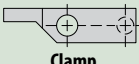

Right-Hand Toolholder Shown

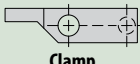
Part Number		Gage 	D.O.C. D	Dimensions (mm)				Std Component  Clamp	*Tune-Up Kit Includes all Standard Components	Optional Components	
Right	Left			A†	B	C	F			 Insert	 Clamp
M-415293-45VGS	M-415294-45VGS	GTS-4125-1	8	25	25	150,5	33,43	415305-GC 415306-GC	TK-02655 TK-02656	GTS-4125	429514-GC 429515-GC
		GTS-4125-2	8	25	25	150,3	33,25				
		WG-4125	8	25	25	150,0	32,92				
		WG-4125-1	8	25	25	150,5	33,43				
		WG-4125-2	8	25	25	150,3	33,25				
		WG-4156	8	25	25	150,1	33,05				
		WG-4156-1	8	25	25	150,6	33,71				
WG-4156-2	8	25	25	150,6	33,53						
M-415295-45VGS	M-415296-45VGS	GTS-4125-1	8	32	32	170,5	40,43	415305-GC 415306-GC	TK-02655 TK-02656	GTS-4125	429514-GC 429515-GC
		GTS-4125-2	8	32	32	170,3	40,26				
		WG-4125	8	32	32	170,0	39,93				
		WG-4125-1	8	32	32	170,5	40,43				
		WG-4125-2	8	32	32	170,3	40,26				
		WG-4156	8	32	32	170,1	40,05				
		WG-4156-1	8	32	32	170,6	40,71				
WG-4156-2	8	32	32	170,6	40,53						
M-415297-45VGS	M-415298-45VGS	GTS-4125-1	8	40	40	200,5	33,43	415305-GC 415306-GC	TK-02655 TK-02656	GTS-4125	429514-GC 429515-GC
		GTS-4125-2	8	40	40	200,3	33,43				
		WG-4125	8	40	40	200,0	47,93				
		WG-4125-1	8	40	40	200,5	48,43				
		WG-4125-2	8	40	40	200,3	48,26				
		WG-4156	8	40	40	200,1	48,05				
		WG-4156-1	8	40	40	200,8	33,43				
WG-4156-2	8	40	40	200,6	33,43						
M-415299-45VGS	M-415300-45VGS	GTS-4187-1	8	25	25	150,83	33,76	415307-GC 415308-GC	TK-02657 TK-02658	GTS-4187	429520-GC 429521-GC
		GTS-4187-2	8	25	25	150,66	33,59				
		WG-4187	8	25	25	150,0	32,92				
		WG-4187-1	8	25	25	150,83	33,76				
		WG-4187-2	8	25	25	150,66	33,58				
M-415301-45VGS	M-415302-45VGS	GTS-4187-1	8	32	32	170,83	40,76	415307-GC 415308-GC	TK-02657 TK-02658	GTS-4187	429520-GC 429521-GC
		GTS-4187-2	8	32	32	170,66	40,59				
		WG-4187	8	32	32	170,00	39,92				
		WG-4187-1	8	32	32	170,83	40,76				
		WG-4187-2	8	32	32	170,66	40,59				
M-415303-45VGS	M-415304-45VGS	GTS-4187-1	8	40	40	200,8	48,76	415307-GC 415308-GC	TK-02657 TK-02658	GTS-4187	429520-GC 429521-GC
		GTS-4187-2	8	40	40	200,7	49,73				
		WG-4187	8	40	40	200,0	47,92				
		WG-4187-1	8	40	40	200,8	48,76				
		WG-4187-2	8	40	40	200,7	48,58				

† "A" indicates width of shank available for clamping, (not necessarily overall shank width).

\* All toolholders include standard clamp and 1/4-20 x 1 SHCS.

GTS is Greenleaf's groove/turn system insert with chip control. Page GP 09.

COS is Greenleaf's cut-off system insert. Page GP 08.

WG is Greenleaf flat-top groover with an 11° nose clearance. Pages GP 10 and GP 11.

WGC is Greenleaf's flat-top groover with a 6° nose clearance. Pages GP 12 and GP 13.

# 90° Grooving/Profiling Toolholder

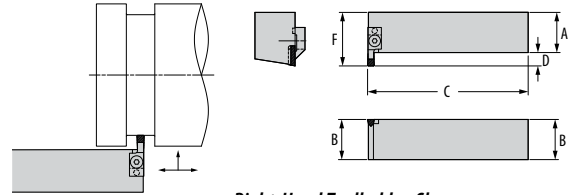

Right-Hand Toolholder Shown

Part Number		Groove Width	D.O.C.	Dimensions (mm)				Standard Components		*Tune-Up Kit	Optional Components	
Right	Left			D	A†	B	C	F	Insert		Clamp	Insert
M-411693-125VGS	–	3,18	10	25	25	150	35	GTS-4125-1 GTS-4125-2 WG-4125 WGC-4125	411765-125GC 411766-125GC 411765-125GC 411766-125GC 411765-125GC 411766-125GC	TK-02659 TK-02660 TK-02659 TK-02660 TK-02659 TK-02660	GTS-4125 COS-4125-0 COS-4125-4R COS-4125-4L	429516-125GC 429517-125GC 429516-125GC 429517-125GC 429516-125GC 429517-125GC
–	M-411694-125VGS	3,18	10	25	25	150	35					
M-411695-125VGS	–	3,18	10	32	32	170	42					
–	M-411696-125VGS	3,18	10	32	32	170	42					
M-411697-125VGS	–	3,18	10	40	40	200	50					
–	M-411698-125VGS	3,18	10	40	40	200	50					
M-411701-156VGS	–	3,96	10	25	25	150	35	WG-4156 WGC-4156	411767-156GC 411768-156GC 411767-156GC 411768-156GC 411767-156GC 411768-156GC	TK-02661 TK-02662 TK-02661 TK-02662 TK-02661 TK-02662	– – – – – –	– – – – – –
–	M-411702-156VGS	3,96	10	25	25	150	35					
M-411703-156VGS	–	3,96	10	32	32	170	42					
–	M-411704-156VGS	3,96	10	32	32	170	42					
M-411705-156VGS	–	3,96	10	40	40	200	50					
–	M-411706-156VGS	3,96	10	40	40	200	50					
M-411709-187VGS	–	4,75	10	25	25	150	35	GTS-4187-1 GTS-4187-2 WG-4187 WGC-4187	411769-187GC 411770-187GC 411769-187GC 411770-187GC 411769-187GC 411770-187GC	TK-02663 TK-02664 TK-02663 TK-02664 TK-02663 TK-02664	GTS-4187 COS-4187-0 COS-4187-4R COS-4187-4L	429522-187GC 429523-187GC 429522-187GC 429523-187GC 429522-187GC 429523-187GC
–	M-411710-187VGS	4,75	10	25	25	150	35					
M-411711-187VGS	–	4,75	10	32	32	170	42					
–	M-411712-187VGS	4,75	10	32	32	170	42					
M-411713-187VGS	–	4,75	10	40	40	200	50					
–	M-411714-187VGS	4,75	10	40	40	200	50					
M-411717-218VGS	–	5,54	13	25	25	150	38	WG-6218 WGC-6218	411771-218GC 411772-218GC 411771-218GC 411772-218GC 411771-218GC 411772-218GC	TK-02665 TK-02666 TK-02665 TK-02666 TK-02665 TK-02666	– – – – – –	– – – – – –
–	M-411718-218VGS	5,54	13	25	25	150	38					
M-411719-218VGS	–	5,54	13	32	32	170	45					
–	M-411720-218VGS	5,54	13	32	32	170	45					
M-411721-218VGS	–	5,54	13	40	40	200	53					
–	M-411722-218VGS	5,54	13	40	40	200	53					
M-411725-250VGS	–	6,35	13	25	25	150	38	GTS-6250 GTS-6250-1 GTS-6250-2 WG-6250 WGC-6250	411773-250GC 411774-250GC 411773-250GC 411774-250GC 411773-250GC 411774-250GC	TK-02667 TK-02668 TK-02667 TK-02668 TK-02667 TK-02668	– – – – – –	– – – – – –
–	M-411726-250VGS	6,35	13	25	25	150	38					
M-411727-250VGS	–	6,35	13	32	32	170	45					
–	M-411728-250VGS	6,35	13	32	32	170	45					
M-411729-250VGS	–	6,35	13	40	40	200	53					
–	M-411730-250VGS	6,35	13	40	40	200	53					

† "A" indicates width of shank available for clamping, (not necessarily overall shank width).

\* All toolholders include standard clamp and 1/4-20 x 1 SHCS.

GTS is Greenleaf's groove/turn system insert with chip control. Page GP 09.

COS is Greenleaf's cut-off system insert. Page GP 08.

WG is Greenleaf flat-top groover with an 11° nose clearance. Pages GP 10 and GP 11.

WGC is Greenleaf's flat-top groover with a 6° nose clearance. Pages GP 12 and GP 13.

Continued on next page.



# 90° Grooving/Profiling Toolholder

(Continued)

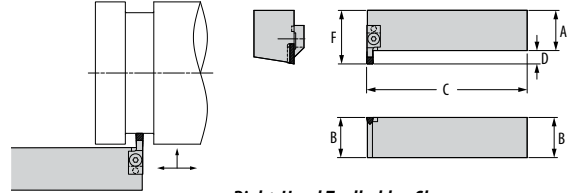

Right-Hand Toolholder Shown

Part Number		Groove Width	D.O.C.	Dimensions (mm)				Standard Components		*Tune-Up Kit	Optional Components	
Right	Left			D	A†	B	C	F	Insert		Clamp	Insert
M-411733-281VGS	–	7,14	13	25	25	150	38	WG-6281	411775-281GC	TK-02669	–	–
–	M-411734-281VGS	7,14	13	25	25	150	38		411776-281GC	TK-02670	–	–
M-411735-281VGS	–	7,14	13	32	32	170	45	WGC-6281	411775-281GC	TK-02669	–	–
–	M-411736-281VGS	7,14	13	32	32	170	45		411776-281GC	TK-02670	–	–
M-411737-281VGS	–	7,14	13	40	40	200	53	WGC-6281	411775-281GC	TK-02669	–	–
–	M-411738-281VGS	7,14	13	40	40	200	53		411776-281GC	TK-02670	–	–
M-411743-312VGS	–	7,92	16	32	32	170	48	WG-8312	411777-312GC	TK-02671	–	–
–	M-411744-312VGS	7,92	16	32	32	170	48		411778-312GC	TK-02672	–	–
M-411745-312VGS	–	7,92	16	40	40	200	56	WGC-8312	411777-312GC	TK-02671	–	–
–	M-411746-312VGS	7,92	16	40	40	200	56		411778-312GC	TK-02672	–	–
M-411751-344VGS	–	8,74	16	32	32	170	48	WG-8344	411779-344GC	TK-02673	–	–
–	M-411752-344VGS	8,74	16	32	32	170	48		411780-344GC	TK-02674	–	–
M-411753-344VGS	–	8,74	16	40	40	200	56	WGC-8344	411779-344GC	TK-02673	–	–
–	M-411754-344VGS	8,74	16	40	40	200	56		411780-344GC	TK-02674	–	–
M-411759-375VGS	–	9,53	16	32	32	170	48	WG-8375	411781-375GC	TK-02675	–	–
–	M-411760-375VGS	9,53	16	32	32	170	48		411782-375GC	TK-02676	–	–
M-411761-375VGS	–	9,53	16	40	40	200	56	WGC-8375	411781-375GC	TK-02675	–	–
–	M-411762-375VGS	9,53	16	40	40	200	56		411782-375GC	TK-02676	–	–

† "A" indicates width of shank available for clamping, (not necessarily overall shank width).

\* All toolholders include standard clamp and 1/4-20 x 1 SHCS.

GTS is Greenleaf's groove/turn system insert with chip control. Page GP 09.

COS is Greenleaf's cut-off system insert. Page GP 08.

WG is Greenleaf flat-top groover with an 11° nose clearance. Pages GP 10 and GP 11.

WGC is Greenleaf's flat-top groover with a 6° nose clearance. Pages GP 12 and GP 13.

# Cut-Off Grooving Bar

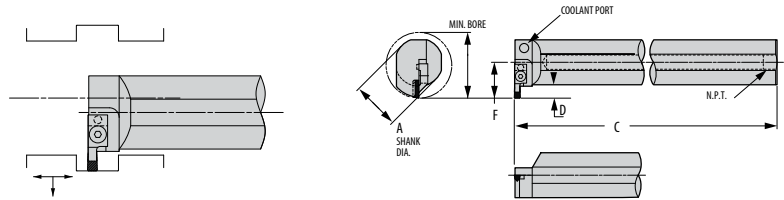

Right-Hand Grooving Bar Shown

Part Number		Groove Width	D.O.C.		Dimensions (mm)			Standard Components		*Tune-Up Kit	Optional Components	
Right	Left		D	Min. Bore	A	C	F	Insert	Clamp	Includes all Standard Components	Insert	Clamp
M-512074-125VGS	-	3,18	10	63	50	400	35	GTS-4125-1	411765-125GC	TK-02659	GTS-4125	429516-125GC
-	M-512075-125VGS	3,18	10	63	50	400	35	GTS-4125-2	411766-125GC	TK-02660	COS-4125-0	429517-125GC
								WG-4125			COS-4125-4R	
								WGC-4125			COS-4125-4L	
M-512086-156VGS	-	3,96	10	63	50	400	35	WG-4156	411767-156GC	TK-02661	-	-
-	M-512087-156VGS	3,96	10	63	50	400	35	WGC-4156	411768-156GC	TK-02662	-	-
M-512098-187VGS	-	4,75	10	63	50	400	35	GTS-4187-1	411769-187GC	TK-02663	GTS-4187	429522-187GC
-	M-512099-187VGS	4,75	10	63	50	400	35	GTS-4187-2	411770-187GC	TK-02664	COS-4187-0	429523-187GC
								WG-4187			COS-4187-4R	
								WGC-4187			COS-4187-4L	
M-512106-218VGS	-	5,54	13	70	50	400	38	WG-6218	411771-218GC	TK-02665	-	-
-	M-512107-218VGS	5,54	13	70	50	400	38	WGC-6218	411772-218GC	TK-02666	-	-
M-512116-250VGS	-	6,35	13	70	50	400	38	GTS-6250	411773-250GC	TK-02667	-	-
-	M-512117-250VGS	6,35	13	70	50	400	38	GTS-6250-1	411774-250GC	TK-02668	-	-
								GTS-6250-2				
								WG-6250				
								WGC-6250				
M-512126-281VGS	-	7,14	13	70	50	400	38	WG-6281	411775-281GC	TK-02669	-	-
-	M-512127-281VGS	7,14	13	70	50	400	38	WGC-6281	411776-281GC	TK-02670	-	-
M-512132-312VGS	-	7,92	16	77	50	400	41	WG-8312	411777-312GC	TK-02671	-	-
-	M-512133-312VGS	7,92	16	77	50	400	41	WGC-8312	411778-312GC	TK-02672	-	-
M-512138-344VGS	-	8,74	16	77	50	400	41	WG-8344	411779-344GC	TK-02673	-	-
-	M-512139-344VGS	8,74	16	77	50	400	41	WGC-8344	411780-344GC	TK-02674	-	-
M-512144-375VGS	-	9,53	16	77	50	400	41	WG-8375	411781-375GC	TK-02675	-	-
-	M-512145-375VGS	9,53	16	77	50	400	41	WGC-8375	411782-375GC	TK-02676	-	-

\* All toolholders include standard clamp and 1/4-20 x 1 SHCS.

GTS is Greenleaf's groove/turn system insert with chip control. Page GP 09.

COS is Greenleaf's cut-off system insert. Page GP 08.

WG is Greenleaf flat-top groover with an 11° nose clearance. Pages GP 10 and GP 11.

WGC is Greenleaf's flat-top groover with a 6° nose clearance. Pages GP 12 and GP 13.

GROOVING, PROFILING, and CUT-OFF

# Cut-Off Grooving Support Blade

For Single-Ended V-Bottom Inserts

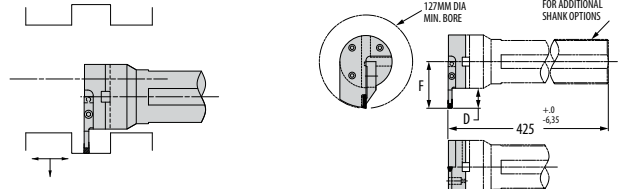

Right-Hand Support Blade Shown

Part Number		Groove Width	D.O.C. D	Dimensions (mm)		Standard Components		*Tune-Up Kit Includes all Std Components and *Clamp Screw	Optional Components	
Right	Left			F	Insert	Clamp	Insert		Clamp	
M-511309-125VGB	—	3,18	19	57,15	GTS-4125-1	411967-125GC	TK-02629	GTS-4125	429513-125GC	
—	M-512228-125VGB	3,18	19	57,15	GTS-4125-2	411966-125GC	TK-02628	COS-4125-0	429512-125GC	
					WG-4125			COS-4125-4R		
					WGC-4125			COS-4125-4L		
M-511311-156VGB	—	3,96	19	57,15	WG-4156	411969-156GC	TK-02631	—	—	
—	M-511312-156VGB	3,96	19	57,15	WGC-4156	411968-156GC	TK-02630	—	—	
M-511313-187VGB	—	4,75	19	57,15	GTS-4187-1	411978-187GC	TK-02633	GTS-4187	429519-187GC	
—	M-511314-187VGB	4,75	19	57,15	GTS-4187-2	411977-187GC	TK-02632	COS-4187-0	429518-187GC	
					WG-4187			COS-4187-4R		
					WGC-4187			COS-4187-4L		
M-511315-218VGB	—	5,54	28,6	66,68	WG-6218	411130-218GC	TK-02635	—	—	
—	M-512229-218VGB	5,54	28,6	66,68	WGC-6218	411979-218GC	TK-02634	—	—	
M-512230-250VGB	—	6,35	28,6	66,68	GTS-6250	411981-250GC	TK-02637	—	—	
—	M-511318-250VGB	6,35	28,6	66,68	GTS-6250-1	411980-250GC	TK-02636	—	—	
					GTS-6250-2					
					WG-6250					
					WGC-6250					
M-511319-281VGB	—	7,14	28,6	66,68	WG-6281	411134-281GC	TK-02648	—	—	
—	M-511320-281VGB	7,14	28,6	66,68	WGC-6281	411133-281GC	TK-02638	—	—	
M-511321-312-VGB	—	7,92	38,1	76,20	WG-8312	411136-312GC	TK-02641	—	—	
—	M-511322-312VGB	7,92	38,1	76,20	WGC-8312	411985-312GC	TK-02640	—	—	
M-511323-344VGB	—	8,74	38,1	76,20	WG-8344	411138-344GC	TK-02643	—	—	
—	M-511324-344VGB	8,74	38,1	76,20	WGC-8344	411137-344GC	TK-02642	—	—	
M-511325-375VGB	—	9,53	38,1	76,20	WG-8375	411987-375GC	TK-02645	—	—	
—	M-511326-375VGB	9,53	38,1	76,20	WGC-8375	411986-375GC	TK-02649	—	—	

NOTE: See page GP 44 for available shank options

\* All toolholders include standard clamp and 1/4-20 x 1 SHCS.

GTS is Greenleaf's groove/turn system insert with chip control. Page GP 09.

COS is Greenleaf's cut-off system insert. Page GP 08.

WG is Greenleaf flat-top groover with an 11° nose clearance. Pages GP 10 and GP 11.

WGC is Greenleaf's flat-top groover with a 6° nose clearance. Pages GP 12 and GP 13.

# Profiling Bar

Round V-Bottom Insert / Milled Nest

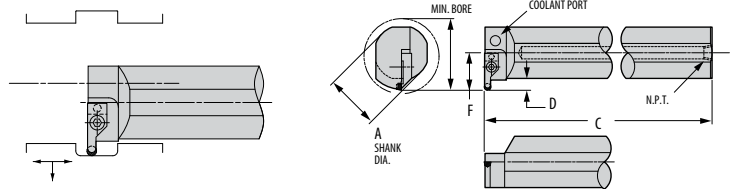

Right-Hand Profiling Bar Shown

Part Number		Gage - Opt 1		Gage - Opt 2		D.O.C.	Dimensions (mm)				Standard Components		*Tune-Up Kit	Opt. Component
Right	Left	Insert	Min. Bore	Insert	Min. Bore	D	A	C	F	Clamp	Clamp Screw	Includes all Standard Components	Insert Screw	
M-519700-06VMRB	-	RPGN-060400	38	RCGN-060400	90	10	25	300	22	412131-250GC	434258	TK-02745	PT-542T	
-	M-519701-06VMRB	RPGN-060400	38	RCGN-060400	90	10	25	300	22	412132-250GC	434258	TK-02746	PT-542T	
M-519702-06VMRB	-	RPGN-060400	45	RCGN-060400	90	10	32	300	25	412131-250GC	434258	TK-02745	PT-542T	
-	M-519703-06VMRB	RPGN-060400	45	RCGN-060400	90	10	32	300	25	412132-250GC	434258	TK-02746	PT-542T	
M-519704-06VMRB	-	RPGN-060400	50	RCGN-060400	90	10	40	350	28	412131-250GC	434258	TK-02745	PT-542T	
-	M-519705-06VMRB	RPGN-060400	50	RCGN-060400	90	10	40	350	28	412132-250GC	434258	TK-02746	PT-542T	
M-519706-06VMRB	-	RPGN-060400	64	RCGN-060400	90	10	50	400	35	412131-250GC	434258	TK-02745	PT-542T	
-	M-519707-06VMRB	RPGN-060400	64	RCGN-060400	90	10	50	400	35	412132-250GC	434258	TK-02746	PT-542T	
M-519708-09VMRB	M-519709-09VMRB	RPGN-090700	57	RCGN-090700	115	13	32	300	29	308063	TSHCS M5-0.8x12mm	TK-02734	PT-545T	
M-519710-09VMRB	M-519711-09VMRB	RPGN-090700	64	RCGN-090700	115	13	40	350	33	308063	TSHCS M5-0.8x12mm	TK-02734	PT-545T	
M-519712-09VMRB	M-519713-09VMRB	RPGN-090700	70	RCGN-090700	115	13	50	400	38	308063	TSHCS M5-0.8x12mm	TK-02734	PT-545T	
M-519714-12VMRB	M-519715-12VMRB	RPGN-120700	57	RCGN-120700	115	16	32	300	32	308136	434258	TK-02691	CO-5018	
M-519716-12VMRB	M-519717-12VMRB	RPGN-120700	64	RCGN-120700	115	16	40	350	35	308136	434258	TK-02691	CO-5018	
M-519718-12VMRB	M-519719-12VMRB	RPGN-120700	70	RCGN-120700	115	16	50	400	41	308136	434258	TK-02691	CO-5018	

NOTE: See page GP 14 for ceramic and carbide inserts.

NOTE: Use carbide inserts RCGT and RPGT with optional insert screw for finishing.

\* Tune-Up Kits include one complete set of Standard Components to allow you to refurbish the profiling bar.



GROOVING, PROFILING, and CUT-OFF

# Profiling Support Blade

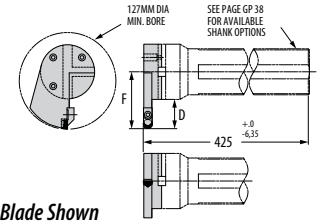
Round V-Bottom Insert / Milled Nest

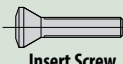
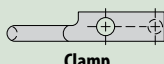

Right-Hand Support Blade Shown

Part Number		Gage 	D.O.C. D	Dimensions (mm)		Standard Components		*Tune-Up Kit Includes all Standard Components	Opt. Component 
Right	Left			F					
M-519740-06VMRB	–	** RPGN-060400	19,05	60,33	411906-250VRC	434259	TK-02690	PT-542T	
–	M-519741-06VMRB	** RPGN-060400	19,05	60,33	411905-250VRC	434259	TK-02689	PT-542T	
M-519742-09VMRB	–	** RPGN-090700	28,60	69,85	308063	TSHCS M5-0.8x16mm	TK-01709	PT-545T	
–	M-519743-09VMRB	** RPGN-090700	28,60	69,85	308063	TSHCS M5-0.8x16mm	TK-01709	PT-545T	
M-519744-12VMRB	–	** RPGN-120700	38,10	79,38	308136	434258	TK-02691	CO-5018	
–	M-519745-12VMRB	** RPGN-120700	38,10	79,38	308136	434258	TK-02691	CO-5018	

NOTE: See page GP 14 for ceramic and carbide inserts.

NOTE: See page GP 44 for available shank options.

NOTE: Use carbide inserts RCGT and RPGT with optional insert screw for finishing.

\* Tune-Up Kits include one complete set of Standard Components to allow you to refurbish the support blade.



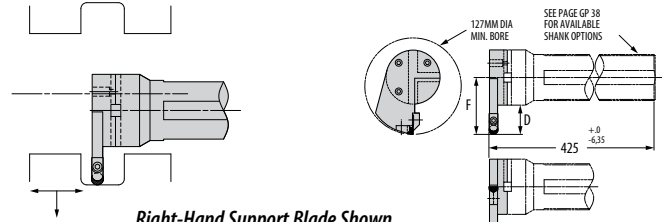

\*\* RCGN can be used in place of RPGN.

# Profiling Support Blade

Round V-Bottom Insert / Replaceable Nest

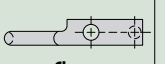

Right-Hand Support Blade Shown

Part Number		Gage 	D.O.C. D	Dimensions (mm)		Standard Components				*Tune-Up Kit Includes all Standard Components
Right	Left			F						
M-512227-06VRB	–	** RPGN-060400	19,05	60,33	411108	BHCS M2.5-0.45x10mm	411906-250VRC	434259	TK-02739	
–	M-511287-06VRB	** RPGN-060400	19,05	60,33	411108	BHCS M2.5-0.45x10mm	411905-250VRC	434259	TK-02740	
M-511288-09VRB	–	** RPGN-090700	28,60	69,85	414009	TBHCS M3-0.5x12mm	308063	TSHCS M5-0.8x12mm	TK-02741	
–	M-511289-09VRB	** RPGN-090700	28,60	69,85	414009	TBHCS M3-0.5x12mm	308063	TSHCS M5-0.8x12mm	TK-02741	
M-511290-12VRB	–	** RPGN-120700	38,10	79,38	414008	TBHCS M5-0.8x16mm	308136	434258	TK-02732	
–	M-511291-12VRB	** RPGN-120700	38,10	79,38	414008	TBHCS M5-0.8x16mm	308136	434258	TK-02732	

NOTE: See page GP 14 for ceramic and carbide inserts.

NOTE: See page GP 44 for available shank options.

\* Tune-Up Kits include one complete set of Standard Components to allow you to refurbish the support blade.

\*\* RCGN can be used in place of RPGN.

# Shank Options

For Bolt-On Support Blades

Part Number	Dimensions (mm)	
Shank Number	A	B
M-529756	50	400
M-529757	60	400
M-529758	72	400

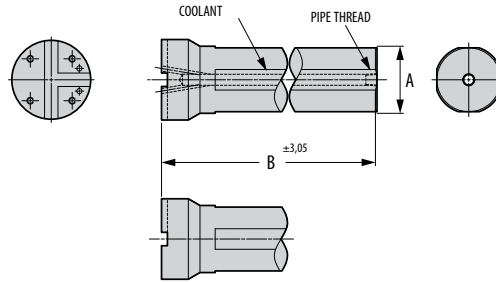

GROOVING, PROFILING, and CUT-OFF

## Grooving, Profiling and Cut-Off Support Blades

The Greenleaf tooling system for grooving, profiling, and cut-off is complemented by a support blade system that combines qualified shanks and support blades to expand the application range of each toolholder or bar. Greenleaf tools can be coupled with 248 support blades holding cut-off, V-bottom round profilers, and grooving inserts to meet your every need.

Quick-change shanks such as CAPTO or KM, as well as straight shank holders and bars, are all part of this tooling system. Custom solutions for particular features not addressable with standard tools can be readily designed with your input and Greenleaf's extensive experience.

### Greenleaf Tune-Up Kits

A Tune-Up Kit consists of all the standard hardware to refurbish a particular toolholder, boring bar, or milling cutter. A toolholder will have a readily visible, laser-inscribed Tune-Up Kit number on it for ease in ordering. This number will prevent any confusion created by searching a catalog for hardware, and it will help reduce downtime.



# Support Blade Overview

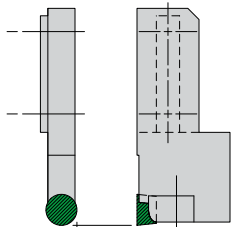

**Round V-Bottom Insert with Replaceable Nest**

3 sizes available using 12 insert combinations

page GP 42

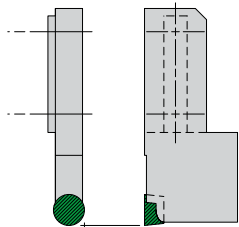

**Round V-Bottom Insert with Milled Nest**

3 sizes available using 18 insert combinations

page GP 42

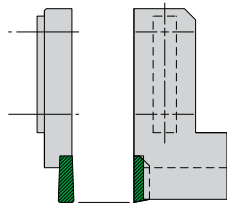

**O.D. Grooving/Profiling Shallow Series**

10 sizes available using 56 insert combinations

page GP 43

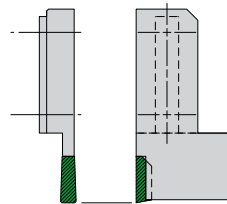

**O.D. Grooving/Profiling Deep Series**

10 sizes available using 56 insert combinations

page GP 43

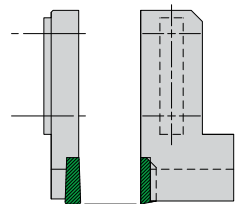

**Face Grooving B Shallow Series**

25 sizes available using 47 insert combinations

page GP 46

## RIGHT HAND

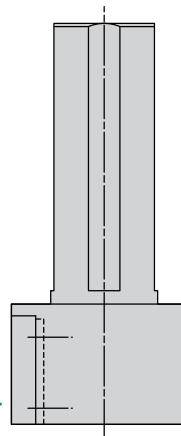

**Round Shanks**

6 sizes available

page GP 52

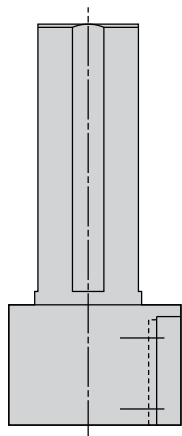

**Straight Shanks**

6 sizes available

page GP 52

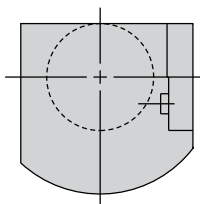
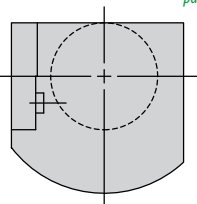

## LEFT HAND

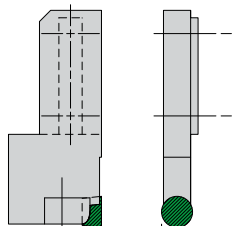

**Round V-Bottom Insert with Replaceable Nest**

3 sizes available using 12 insert combinations

page GP 42

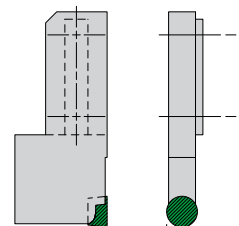

**Round V-Bottom Insert with Milled Nest**

3 sizes available using 18 insert combinations

page GP 42

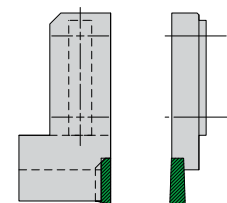

**O.D. Grooving/Profiling Shallow Series**

10 sizes available using 56 insert combinations

page GP 44

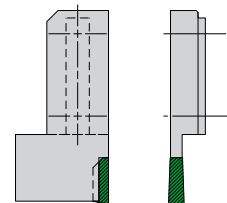

**O.D. Grooving/Profiling Deep Series**

10 sizes available using 56 insert combinations

page GP 44

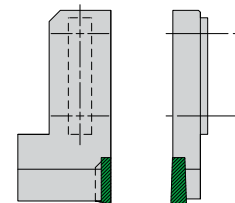

**Face Grooving C Shallow Series**

25 sizes available using 47 insert combinations

page GP 47

GROOVING, PROFILING, and CUT-OFF



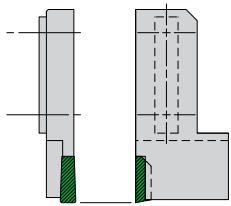

**Face Grooving B Deep Series**  
25 sizes available using 47 insert combinations

page GP 46

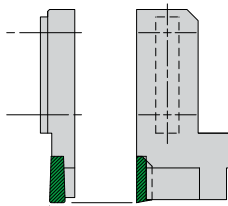

**Face Grooving A Shallow Series**  
25 sizes available using 47 insert combinations

page GP 45

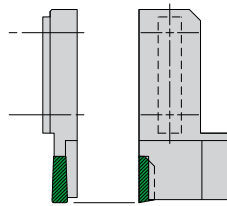

**Face Grooving A Deep Series**  
25 sizes available using 47 insert combinations

page GP 45

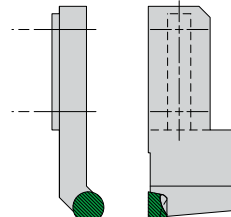

**Special Designs to Fit Customer's Parts**

page GP 50-51

**RIGHT HAND**

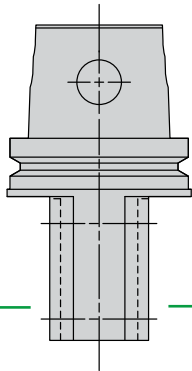

**KM Tool Shanks**  
4 sizes available

page GP 53

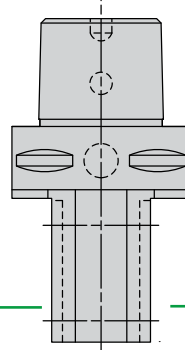
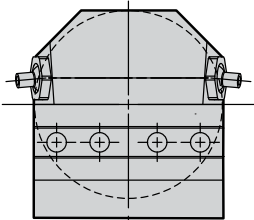
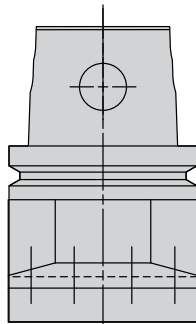

**ISO 26623 Tool Shanks**  
4 sizes available

page GP 53

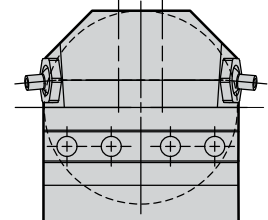
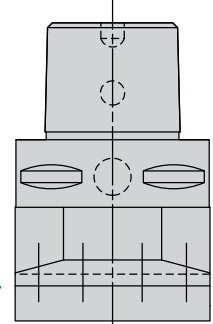

**LEFT HAND**

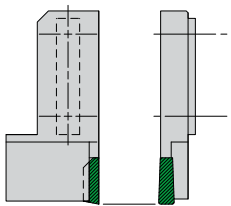

**Face Grooving C Deep Series**  
25 sizes available using 47 insert combinations

page GP 47

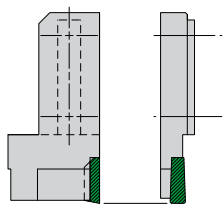

**Face Grooving D Shallow Series**  
25 sizes available using 47 insert combinations

page GP 48

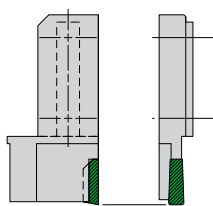

**Face Grooving D Deep Series**  
25 sizes available using 47 insert combinations

page GP 48

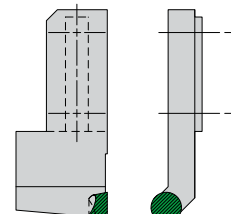

**Special Designs to Fit Customer's Parts**

page GP 50-51

# O.D. Grooving/Profiling Support Blade

Round V-Bottom Insert Replaceable Nest

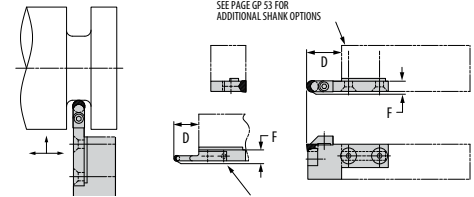

Right-Hand Support Blade Shown

Part Number		Gage 	D.O.C.	Dimensions (mm)		Standard Components				*Tune-Up Kit
Right	Left			D	F					Includes all Standard Components
M-411959-06VR	—	** RPGN-060400	19,05	11,91	410631	BHCS M2.5-0.45x10mm	411905-250VRC	434259	TK-02692	
—	M-411960-06VR	** RPGN-060400	19,05	11,91	410631	BHCS M2.5-0.45x10mm	411906-250VRC	434259	TK-02693	
M-411011-09VR	M-411012-09VR	** RPGN-090700	28,60	11,91	413970	TBHCs M3-0.5x12mm	308063	TSHCS M5-0.8x12mm	TK-02685	
M-411009-12VR	M-411010-12VR	** RPGN-120700	38,10	11,91	414007	TBHCs M5-0.8x16mm	308136	434258	TK-02686	

\* Tune-Up Kits include one complete set of Standard Components to allow you to refurbish the support blade.

\*\* RCGN can be used in place of RPGN.

See pages GP 60-62 for additional shank options.

See page GP 14 for ceramic and carbide insert.

# O.D. Grooving/Profiling Support Blade

Round V-Bottom Insert Milled Nest

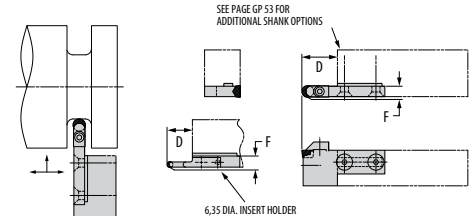

Right-Hand Support Blade Shown

Part Number		Gage 	D.O.C.	Dimensions (mm)		Standard Components		*Tune-Up Kit	Optional Component
Right	Left			D	F			Includes all Standard Components	
M-421534-06VMR	—	** RPGN-060400	19,05	11,91	411905-250VRC	434259	TK-02689	PT-542T	
—	M-421535-06VMR	** RPGN-060400	19,05	11,91	411906-250VRC	434259	TK-02690	PT-542T	
M-421536-09VMR	M-421537-09VMR	** RPGN-090700	28,60	11,91	308063	TSHCS M5-0.8x12mm	TK-02734	PT-545T	
M-421538-12VMR	M-421539-12VMR	** RPGN-120700	38,10	11,91	308136	434258	TK-02691	CO-5018	

\* Tune-Up Kits include one complete set of Standard Components to allow you to refurbish the support blade.

\*\* RCGN can be used in place of RPGN.

See pages GP 60-62 for additional shank options.

See page GP 14 for ceramic and carbide insert.

NOTE: Use carbide inserts RCGT and RPQT with optional insert screw for finishing.

GROOVING, PROFILING, and CUT-OFF

# O.D. Grooving/Profiling/ Cut-Off Support Blade *Right Hand*

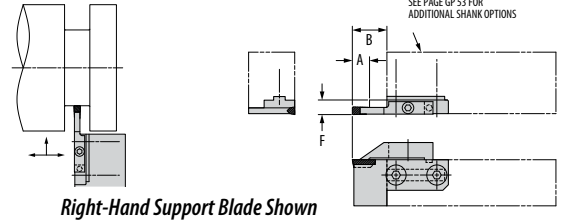

Right-Hand Support Blade Shown

Part Number		Groove Width	Dimensions (mm)			Standard Components		*Tune-Up Kit	Optional Components	
Shallow Series	Deep Series		A	B	F	Insert	Clamp	Includes all Std Components and *Clamp Screw	Insert	Clamp
M-427647-094VG		2,39	9,6	–	11,91	WG-4094	427651-094GC	TK-02626	COS-4094-0	429524-094GC
	M-427648-094VG		–	19	11,91	WGC-4094	427651-094GC	TK-02626	COS-4094-4L	429524-094GC
									COS-4094-4R	
M-421109-125VG		3,18	9,6	–	11,91	GTS-4125-1	411966-125GC	TK-02628	GTS-4125	429512-125GC
	M-411988-125VG		–	19	11,91	GTS-4125-2	411966-125GC	TK-02628	COS-4125-0	429512-125GC
						WG-4125			COS-4125-4R	
						WGC-4125			COS-4125-4L	
M-421110-156VG		3,96	9,6	–	11,91	WG-4156	411968-156GC	TK-02630	–	–
	M-411066-156VG		–	19	11,91	WGC-4156	411968-156GC	TK-02630		
M-421111-187VG		4,75	9,6	–	11,91	GTS-4187-1	411977-187GC	TK-02632	GTS-4187	429518-187GC
	M-411068-187VG		–	19	11,91	GTS-4187-2	411977-187GC	TK-02632	COS-4187-0	429518-187GC
						WG-4187			COS-4187-4R	
						WGC-4187			COS-4187-4L	
M-421112-218VG		5,54	14,2	–	11,91	WG-6218	411979-218GC	TK-02634	–	–
	M-411081-218VG		–	28,7	11,91	WGC-6218	411979-218GC	TK-02634		
M-421113-250VG		6,35	14,2	–	11,91	WG-6250	411980-250GC	TK-02636	–	–
	M-411992-250VG		–	28,7	11,91	WGC-6250	411980-250GC	TK-02636		
						GTS-6250				
						GTS-6250-1				
						GTS-6250-2				
M-421114-281VG		7,14	14,2	–	11,91	WG-6281	411133-281GC	TK-02638	–	–
	M-411085-281VG		–	28,7	11,91	WGC-6281	411133-281GC	TK-02638		
M-421115-312VG		7,92	19	–	11,91	WG-8312	411985-312GC	TK-02640	–	–
	M-411087-312VG		–	38,1	11,91	WGC-8312	411985-312GC	TK-02640		
M-421116-344VG		8,74	19	–	11,91	WG-8344	411137-344GC	TK-02642	–	–
	M-411089-344VG		–	38,1	11,91	WGC-8344	411137-344GC	TK-02642		
M-421117-375VG		9,53	19	–	11,91	WG-8375	411986-375GC	TK-02649	–	–
	M-411994-375VG		–	38,1	11,91	WGC-8375	411986-375GC	TK-02649		

\* Tune-Up Kits include one complete set of Standard Components to allow you to refurbish the support blade.

All support blades include Standard Clamp and 1/4-20 x 1 SHCS.

GTS is Greenleaf's groove/turn system insert with chip control. Page GP 09.

COS is Greenleaf's cut-off system insert. Page GP 08.

WG is Greenleaf flat-top groover with an 11° nose clearance. See pages GP 10 and GP 11.

WGC is Greenleaf's flat-top groover with a 6° nose clearance. See pages GP 12 and GP 13.

See pages GP 60-62 for additional shank options.

# O.D. Grooving/Profiling/ Cut-Off Support Blade *Left Hand*

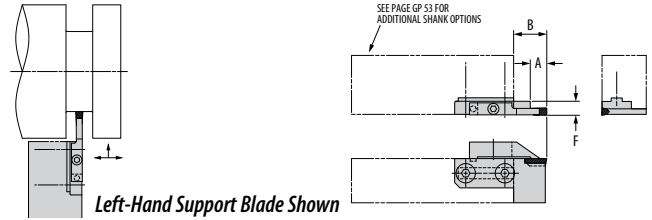

Left-Hand Support Blade Shown

Part Number		Groove Width	Dimensions (mm)			Standard Components		*Tune-Up Kit	Optional Components	
Shallow Series	Deep Series		A	B	F	Insert	Clamp	Includes all Std Components and *Clamp Screw	Insert	Clamp
M-427649-094VG		2,39	9,6	–	11,91	WG-4094	427652-094GC	TK-02627	COS-4094-0	429525-094GC
	M-427650-094VG		–	19,05	11,91	WGC-4094	427652-094GC	TK-02627	COS-4094-4L	429525-094GC
									COS-4094-4R	
M-421100-125VG		3,18	9,6	–	11,91	GTS-4125-1	411967-125GC	TK-02629	GTS-4125	429513-125GC
	M-411989-125VG		–	19,05	11,91	GTS-4125-2	411967-125GC	TK-02629	COS-4125-0	429513-125GC
					WG-4125				COS-4125-4R	
					WGC-4125				COS-4125-4L	
M-421101-156VG		3,96	9,6	–	11,91	WG-4156	411969-156GC	TK-02631	–	–
	M-411990-156VG		–	19,05	11,91	WGC-4156	411969-156GC	TK-02631		
M-421102-187VG		4,75	9,6	–	11,91	GTS-4187-1	411978-187GC	TK-02633	GTS-4187	429519-187GC
	M-411991-187VG		–	19,05	11,91	GTS-4187-2	411978-187GC	TK-02633	COS-4187-0	429519-187GC
					WG-4187				COS-4187-4R	
					WGC-4187				COS-4187-4L	
M-421103-218VG		5,54	14,2	–	11,91	WG-6218	411130-218GC	TK-02635	–	–
	M-411082-218VG		–	28,7	11,91	WGC-6218	411130-218GC	TK-02635		
M-421104-250VG		6,35	14,2	–	11,91	WG-6250	411981-250GC	TK-02637	–	–
	M-411993-250VG		–	28,7	11,91	WGC-6250	411981-250GC	TK-02637		
					GTS-6250					
					GTS-6250-1					
					GTS-6250-2					
M-421105-281VG		7,14	14,2	–	11,91	WG-6281	411134-281GC	TK-02648	–	–
	M-411086-281VG		–	28,7	11,91	WGC-6281	411134-281GC	TK-02648		
M-421106-312VG		7,92	19	–	11,91	WG-8312	411136-312GC	TK-02641	–	–
	M-411088-312VG		–	38,1	11,91	WGC-8312	411136-312GC	TK-02641		
M-421107-344VG		8,74	19	–	11,91	WG-8344	411138-344GC	TK-02643	–	–
	M-411090-344VG		–	38,1	11,91	WGC-8344	411138-344GC	TK-02643		
M-421108-375VG		9,53	19	–	11,91	WG-8375	411987-375GC	TK-02645	–	–
	M-411122-375VG		–	38,1	11,91	WGC-8375	411987-375GC	TK-02645		

\* Tune-Up Kits include one complete set of Standard Components to allow you to refurbish the support blade.

All support blades include Standard Clamp and 1/4-20 x 1 SHCS.

GTS is Greenleaf's groove/turn system insert with chip control. Page GP 09.

COS is Greenleaf's cut-off system insert. Page GP 08.

WG is Greenleaf flat-top groover with an 11° nose clearance. Pages GP 10 and GP 11.

WGC is Greenleaf's flat-top groover with a 6° nose clearance. Pages GP 12 and GP 13.

See pages GP 60-62 for additional shank options.

# Face Grooving Support Blade A

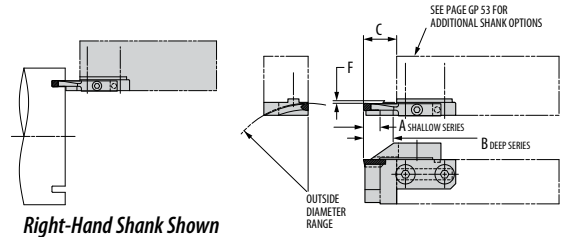

Right-Hand Shank Shown

Part Number		Gage 	Outside Diameter Range	Dimensions (mm)				Standard Components		*Tune-Up Kit
Shallow Series	Deep Series			A	B	C	F	 Clamp	 Clamp Screw	Includes all Standard Components
M-421218-125S-030	M-421243-125L-030	WG-4125	76,20 - 88,90	9,65	16	19,05	0,79	421323-125GC	434259	TK-02650
M-421219-125S-035	M-421244-125L-035	WG-4125	88,90 - 107,95	9,65	16	19,05	0,79	421323-125GC	434259	TK-02650
M-421220-125S-0425	M-421245-125L-0425	WG-4125	107,95 - 139,70	9,65	16	19,05	0,79	421323-125GC	434259	TK-02650
M-421221-125S-055	M-421246-125L-055	WG-4125	139,70 - 190,50	9,65	16	19,05	0,79	421323-125GC	434259	TK-02650
M-421222-125S-075	M-421247-125L-075	WG-4125	190,50 - 317,50	9,65	16	19,05	0,79	421323-125GC	434259	TK-02650
M-421223-125S-125	M-421248-125L-125	WG-4125	317,50 - 1016,0	9,65	16	19,05	0,79	421323-125GC	434259	TK-02650
M-421224-187S-030	M-421249-187L-030	WG-4187	76,20 - 88,90	9,65	16	19,05	0,79	421324-187GC	434259	TK-02651
M-421225-187S-035	M-421250-187L-035	WG-4187	88,90 - 107,95	9,65	16	19,05	0,79	421324-187GC	434259	TK-02651
M-421226-187S-0425	M-421251-187L-0425	WG-4187	107,95 - 139,70	9,65	16	19,05	0,79	421324-187GC	434259	TK-02651
M-421227-187S-055	M-421252-187L-055	WG-4187	139,70 - 190,50	9,65	16	19,05	0,79	421324-187GC	434259	TK-02651
M-421228-187S-075	M-421253-187L-075	WG-4187	190,50 - 317,50	9,65	16	19,05	0,79	421324-187GC	434259	TK-02651
M-421229-187S-125	M-421254-187L-125	WG-4187	317,50 - 1016,0	9,65	16	19,05	0,79	421324-187GC	434259	TK-02651
M-421230-250S-030	M-421255-250L-030	WG-6250	76,20 - 107,95	14,22	25,40	28,58	0,79	421325-250GC	434259	TK-02652
M-421231-250S-0425	M-421256-250L-0425	WG-6250	107,95 - 152,40	14,22	25,40	28,58	0,79	421325-250GC	434259	TK-02652
M-421232-250S-060	M-421257-250L-060	WG-6250	152,40 - 215,90	14,22	25,40	28,58	0,79	421325-250GC	434259	TK-02652
M-421233-250S-085	M-421258-250L-085	WG-6250	215,90 - 393,70	14,22	25,40	28,58	0,79	421325-250GC	434259	TK-02652
M-421234-250S-155	M-421259-250L-155	WG-6250	393,70 - 1016,0	14,22	25,40	28,58	0,79	421325-250GC	434259	TK-02652
M-421235-312S-030	M-421260-312L-030	WG-8312	76,20 - 127,00	19,05	33,27	38,10	0,79	421326-312GC	434259	TK-02653
M-421236-312S-050	M-421261-312L-050	WG-8312	127,00 - 228,60	19,05	33,27	38,10	0,79	421326-312GC	434259	TK-02653
M-421237-312S-090	M-421262-312L-090	WG-8312	228,60 - 482,60	19,05	33,27	38,10	0,79	421326-312GC	434259	TK-02653
M-421238-312S-190	M-421263-312L-190	WG-8312	482,60 -	19,05	33,27	38,10	0,79	421326-312GC	434259	TK-02653
M-421239-375S-030	M-421264-375L-030	WG-8375	76,20 - 127,00	19,05	33,27	38,10	0,79	421327-375GC	434259	TK-02654
M-421240-375S-050	M-421265-375L-050	WG-8375	127,00 - 228,60	19,05	33,27	38,10	0,79	421327-375GC	434259	TK-02654
M-421241-375S-090	M-421266-375L-090	WG-8375	228,60 - 482,60	19,05	33,27	38,10	0,79	421327-375GC	434259	TK-02654
M-421242-375S-190	M-421267-375L-190	WG-8375	482,60 -	19,05	33,27	38,10	0,79	421327-375GC	434259	TK-02654

\* Tune-Up Kits include one complete set of Standard Components to allow you to refurbish the support blade.  
See pages GP 60-62 for additional shank options.  
See pages GP 10 and GP 11 for inserts.

# Face Grooving Support Blade B

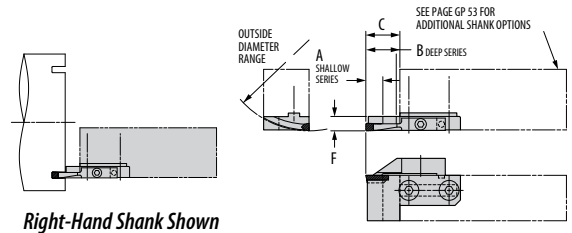

Right-Hand Shank Shown

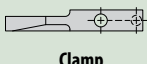
Part Number		Gage 	Outside Diameter Range	Dimensions (mm)				Standard Components		*Tune-Up Kit Includes all Standard Components
Shallow Series	Deep Series			A	B	C	F	 Clamp	 Clamp Screw	
M-421118-125S-030	M-421143-125L-030	WG-4125	76,20 - 88,90	9,65	16	19,05	11,91	421318-125GC	434259	TK-02677
M-421119-125S-035	M-421144-125L-035	WG-4125	88,90 - 107,95	9,65	16	19,05	11,91	421318-125GC	434259	TK-02677
M-421120-125S-0425	M-421145-125L-0425	WG-4125	107,95 - 139,70	9,65	16	19,05	11,91	421318-125GC	434259	TK-02677
M-421121-125S-055	M-421146-125L-055	WG-4125	139,70 - 190,50	9,65	16	19,05	11,91	421318-125GC	434259	TK-02677
M-421122-125S-075	M-421147-125L-075	WG-4125	190,50 - 317,50	9,65	16	19,05	11,91	421318-125GC	434259	TK-02677
M-421123-125S-125	M-421148-125L-125	WG-4125	317,50 - 1016,0	9,65	16	19,05	11,91	421318-125GC	434259	TK-02677
M-421124-187S-030	M-421149-187L-030	WG-4187	76,20 - 88,90	9,65	16	19,05	11,91	421319-187GC	434259	TK-02678
M-421125-187S-035	M-421150-187L-035	WG-4187	88,90 - 107,95	9,65	16	19,05	11,91	421319-187GC	434259	TK-02678
M-421126-187S-0425	M-421151-187L-0425	WG-4187	107,95 - 139,70	9,65	16	19,05	11,91	421319-187GC	434259	TK-02678
M-421127-187S-055	M-421152-187L-055	WG-4187	139,70 - 190,50	9,65	16	19,05	11,91	421319-187GC	434259	TK-02678
M-421128-187S-075	M-421153-187L-075	WG-4187	190,50 - 317,50	9,65	16	19,05	11,91	421319-187GC	434259	TK-02678
M-421129-187S-125	M-421154-187L-125	WG-4187	317,50 - 1016,0	9,65	16	19,05	11,91	421319-187GC	434259	TK-02678
M-421130-250S-030	M-421155-250L-030	WG-6250	76,20 - 107,95	14,22	25,40	28,58	11,91	421320-250GC	434259	TK-02679
M-421131-250S-0425	M-421156-250L-0425	WG-6250	107,95 - 152,40	14,22	25,40	28,58	11,91	421320-250GC	434259	TK-02679
M-421132-250S-060	M-421157-250L-060	WG-6250	152,40 - 215,90	14,22	25,40	28,58	11,91	421320-250GC	434259	TK-02679
M-421133-250S-085	M-421158-250L-085	WG-6250	215,90 - 393,70	14,22	25,40	28,58	11,91	421320-250GC	434259	TK-02679
M-421134-250S-155	M-421159-250L-155	WG-6250	393,70 - 1016,0	14,22	25,40	28,58	11,91	421320-250GC	434259	TK-02679
M-421135-312S-030	M-421160-312L-030	WG-8312	76,20 - 127,00	19,05	33,27	38,10	11,91	421321-312GC	434259	TK-02680
M-421136-312S-050	M-421161-312L-050	WG-8312	127,00 - 228,60	19,05	33,27	38,10	11,91	421321-312GC	434259	TK-02680
M-421137-312S-090	M-421162-312L-090	WG-8312	228,60 - 482,60	19,05	33,27	38,10	11,91	421321-312GC	434259	TK-02680
M-421138-312S-190	M-421163-312L-190	WG-8312	482,60 -	19,05	33,27	38,10	11,91	421321-312GC	434259	TK-02680
M-421139-375S-030	M-421164-375L-030	WG-8375	76,20 - 127,00	19,05	33,27	38,10	11,91	421322-375GC	434259	TK-02681
M-421140-375S-050	M-421165-375L-050	WG-8375	127,00 - 228,60	19,05	33,27	38,10	11,91	421322-375GC	434259	TK-02681
M-421141-375S-090	M-421166-375L-090	WG-8375	228,60 - 482,60	19,05	33,27	38,10	11,91	421322-375GC	434259	TK-02681
M-421142-375S-190	M-421167-375L-190	WG-8375	482,60 -	19,05	33,27	38,10	11,91	421322-375GC	434259	TK-02681

\* Tune-Up Kits include one complete set of Standard Components to allow you to refurbish the support blade.  
See pages GP 60-62 for additional shank options.  
See pages GP 10 and GP 11 for inserts.

GROOVING, PROFILING, and CUT-OFF

# Face Grooving Support Blade C

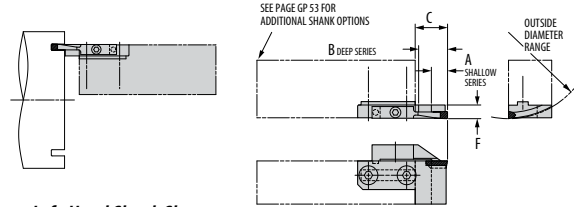

Part Number		Gage 	Outside Diameter Range	Dimensions (mm)				Standard Components		*Tune-Up Kit
Shallow Series	Deep Series			A	B	C	F	 Clamp	 Clamp Screw	Includes all Standard Components
M-421168-125S-030	M-421193-125L-030	WG-4125	76,20 - 88,90	9,65	16	19,05	11,91	421323-125GC	434259	TK-02650
M-421169-125S-035	M-421194-125L-035	WG-4125	88,90 - 107,95	9,65	16	19,05	11,91	421323-125GC	434259	TK-02650
M-421170-125S-0425	M-421195-125L-0425	WG-4125	107,95 - 139,70	9,65	16	19,05	11,91	421323-125GC	434259	TK-02650
M-421171-125S-055	M-421196-125L-055	WG-4125	139,70 - 190,50	9,65	16	19,05	11,91	421323-125GC	434259	TK-02650
M-421172-125S-075	M-421197-125L-075	WG-4125	190,50 - 317,50	9,65	16	19,05	11,91	421323-125GC	434259	TK-02650
M-421173-125S-125	M-421198-125L-125	WG-4125	317,50 - 1016,0	9,65	16	19,05	11,91	421323-125GC	434259	TK-02650
M-421174-187S-030	M-421199-187L-030	WG-4187	76,20 - 88,90	9,65	16	19,05	11,91	421324-187GC	434259	TK-02651
M-421175-187S-035	M-421200-187L-035	WG-4187	88,90 - 107,95	9,65	16	19,05	11,91	421324-187GC	434259	TK-02651
M-421176-187S-0425	M-421201-187L-0425	WG-4187	107,95 - 139,70	9,65	16	19,05	11,91	421324-187GC	434259	TK-02651
M-421177-187S-055	M-421202-187L-055	WG-4187	139,70 - 190,50	9,65	16	19,05	11,91	421324-187GC	434259	TK-02651
M-421178-187S-075	M-421203-187L-075	WG-4187	190,50 - 317,50	9,65	16	19,05	11,91	421324-187GC	434259	TK-02651
M-421179-187S-125	M-421204-187L-125	WG-4187	317,50 - 1016,0	9,65	16	19,05	11,91	421324-187GC	434259	TK-02651
M-421180-250S-030	M-421205-250L-030	WG-6250	76,20 - 107,95	14,22	25,40	28,58	11,91	421325-250GC	434259	TK-02652
M-421181-250S-0425	M-421206-250L-0425	WG-6250	107,95 - 152,40	14,22	25,40	28,58	11,91	421325-250GC	434259	TK-02652
M-421182-250S-060	M-421207-250L-060	WG-6250	152,40 - 215,90	14,22	25,40	28,58	11,91	421325-250GC	434259	TK-02652
M-421183-250S-085	M-421208-250L-085	WG-6250	215,90 - 393,70	14,22	25,40	28,58	11,91	421325-250GC	434259	TK-02652
M-421184-250S-155	M-421209-250L-155	WG-6250	393,70 - 1016,0	14,22	25,40	28,58	11,91	421325-250GC	434259	TK-02652
M-421185-312S-030	M-421210-312L-030	WG-8312	76,20 - 127,00	19,05	33,27	38,10	11,91	421326-312GC	434259	TK-02653
M-421186-312S-050	M-421211-312L-050	WG-8312	127,00 - 228,60	19,05	33,27	38,10	11,91	421326-312GC	434259	TK-02653
M-421187-312S-090	M-421212-312L-090	WG-8312	228,60 - 482,60	19,05	33,27	38,10	11,91	421326-312GC	434259	TK-02653
M-421188-312S-190	M-421213-312L-190	WG-8312	482,60 -	19,05	33,27	38,10	11,91	421326-312GC	434259	TK-02653
M-421189-375S-030	M-421214-375L-030	WG-8375	76,20 - 127,00	19,05	33,27	38,10	11,91	421327-375GC	434259	TK-02654
M-421190-375S-050	M-421215-375L-050	WG-8375	127,00 - 228,60	19,05	33,27	38,10	11,91	421327-375GC	434259	TK-02654
M-421191-375S-090	M-421216-375L-090	WG-8375	228,60 - 482,60	19,05	33,27	38,10	11,91	421327-375GC	434259	TK-02654
M-421192-375S-190	M-421217-375L-190	WG-8375	482,60 -	19,05	33,27	38,10	11,91	421327-375GC	434259	TK-02654

\* Tune-Up Kits include one complete set of Standard Components to allow you to refurbish the support blade.  
See pages GP 60-62 for additional shank options.  
See pages GP 10 and GP 11 for inserts.

# Face Grooving Support Blade D

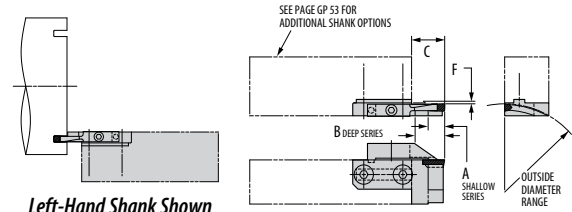

Left-Hand Shank Shown

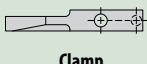
Part Number		Gage 	Outside Diameter Range	Dimensions (mm)				Standard Components		*Tune-Up Kit
Shallow Series	Deep Series			A	B	C	F			Includes all Standard Components
M-421268-125S-030	M-421293-125L-030	WG-4125	76,20 - 88,90	9,65	16	19,05	0,79	421318-125GC	434259	TK-02677
M-421269-125S-035	M-421294-125L-035	WG-4125	88,90 - 107,95	9,65	16	19,05	0,79	421318-125GC	434259	TK-02677
M-421270-125S-0425	M-421295-125L-0425	WG-4125	107,95 - 139,70	9,65	16	19,05	0,79	421318-125GC	434259	TK-02677
M-421271-125S-055	M-421296-125L-055	WG-4125	139,70 - 190,50	9,65	16	19,05	0,79	421318-125GC	434259	TK-02677
M-421272-125S-075	M-421297-125L-075	WG-4125	190,50 - 317,50	9,65	16	19,05	0,79	421318-125GC	434259	TK-02677
M-421273-125S-125	M-421298-125L-125	WG-4125	317,50 - 1016,0	9,65	16	19,05	0,79	421318-125GC	434259	TK-02677
M-421274-187S-030	M-421299-187L-030	WG-4187	76,20 - 88,90	9,65	16	19,05	0,79	421319-187GC	434259	TK-02678
M-421275-187S-035	M-421300-187L-035	WG-4187	88,90 - 107,95	9,65	16	19,05	0,79	421319-187GC	434259	TK-02678
M-421276-187S-0425	M-421301-187L-0425	WG-4187	107,95 - 139,70	9,65	16	19,05	0,79	421319-187GC	434259	TK-02678
M-421277-187S-055	M-421302-187L-055	WG-4187	139,70 - 190,50	9,65	16	19,05	0,79	421319-187GC	434259	TK-02678
M-421278-187S-075	M-421303-187L-075	WG-4187	190,50 - 317,50	9,65	16	19,05	0,79	421319-187GC	434259	TK-02678
M-421279-187S-125	M-421304-187L-125	WG-4187	317,50 - 1016,0	9,65	16	19,05	0,79	421319-187GC	434259	TK-02678
M-421280-250S-030	M-421305-250L-030	WG-6250	76,20 - 107,95	14,22	25,40	28,58	0,79	421320-250GC	434259	TK-02679
M-421281-250S-0425	M-421306-250L-0425	WG-6250	107,95 - 152,40	14,22	25,40	28,58	0,79	421320-250GC	434259	TK-02679
M-421282-250S-060	M-421307-250L-060	WG-6250	152,40 - 215,90	14,22	25,40	28,58	0,79	421320-250GC	434259	TK-02679
M-421283-250S-085	M-421308-250L-085	WG-6250	215,90 - 393,70	14,22	25,40	28,58	0,79	421320-250GC	434259	TK-02679
M-421284-250S-155	M-421309-250L-155	WG-6250	393,70 - 1016,0	14,22	25,40	28,58	0,79	421320-250GC	434259	TK-02679
M-421285-312S-030	M-421310-312L-030	WG-8312	76,20 - 127,00	19,05	33,27	38,10	0,79	421321-312GC	434259	TK-02680
M-421286-312S-050	M-421311-312L-050	WG-8312	127,00 - 228,60	19,05	33,27	38,10	0,79	421321-312GC	434259	TK-02680
M-421287-312S-090	M-421312-312L-090	WG-8312	228,60 - 482,60	19,05	33,27	38,10	0,79	421321-312GC	434259	TK-02680
M-421288-312S-190	M-421313-312L-190	WG-8312	482,60 -	19,05	33,27	38,10	0,79	421321-312GC	434259	TK-02680
M-421289-375S-030	M-421314-375L-030	WG-8375	76,20 - 127,00	19,05	33,27	38,10	0,79	421322-375GC	434259	TK-02681
M-421290-375S-050	M-421315-375L-050	WG-8375	127,00 - 228,60	19,05	33,27	38,10	0,79	421322-375GC	434259	TK-02681
M-421291-375S-090	M-421316-375L-090	WG-8375	228,60 - 482,60	19,05	33,27	38,10	0,79	421322-375GC	434259	TK-02681
M-421292-375S-190	M-421317-375L-190	WG-8375	482,60 -	19,05	33,27	38,10	0,79	421322-375GC	434259	TK-02681

\* Tune-Up Kits include one complete set of Standard Components to allow you to refurbish the support blade.  
See pages GP 60-62 for additional shank options.  
See pages GP 10 and GP 11 for inserts.

GROOVING, PROFILING, and CUT-OFF





# Technical Data

## Face Grooving Tools - Ordering Instructions

Face grooving tools must be matched to a specific radius and are, therefore, manufactured to order for your particular application.

We offer tools either with integral support blades (SFG) or with separate replaceable blades (AFG). Four combinations are available relative to hand of tool and hand of radius.

When ordering replaceable blade styles, we suggest the purchase of additional back-up blades at time of original order.

For your convenience in ordering or request for quotation, we have published sample blank engineering data forms. You must provide ALL of the dimensional data listed to ensure the correct tool being manufactured.

*Note: Tools will be quoted either with radius relieved blades or angular relieved blades, according to groove diameter. Radius relieved blades are illustrated.*

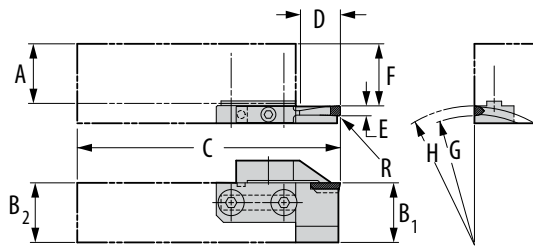

AFGVLL

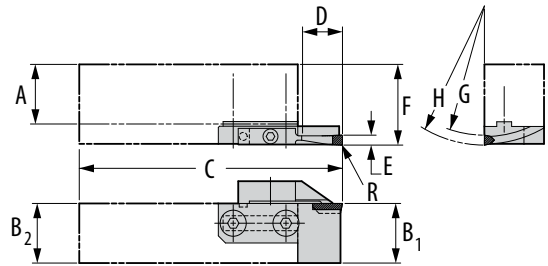

AFGVLR

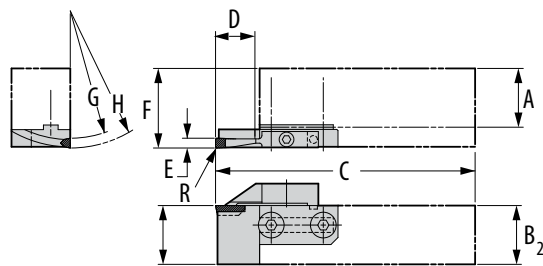

AFGVRL

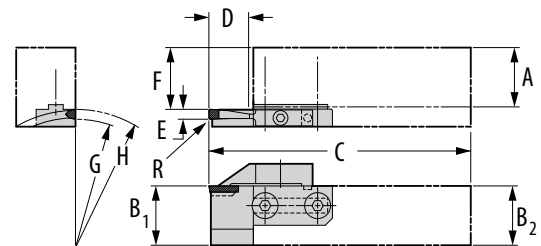

AFGVRR

<b>AFGV__</b>	A	C	F
Drawing #	B <sub>1</sub>	D (depth of cut)	G (radius)
R (radius)	B <sub>2</sub>	E	H (radius)

GROOVING, PROFILING, and CUT-OFF

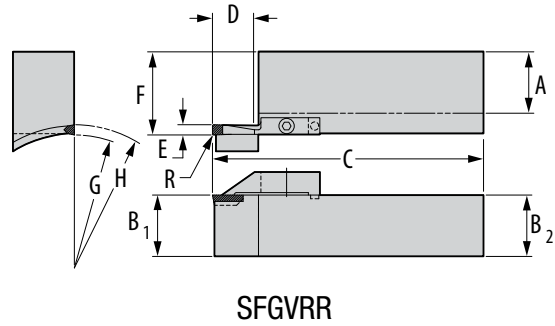
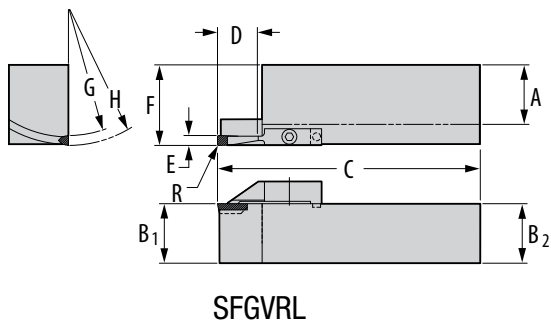
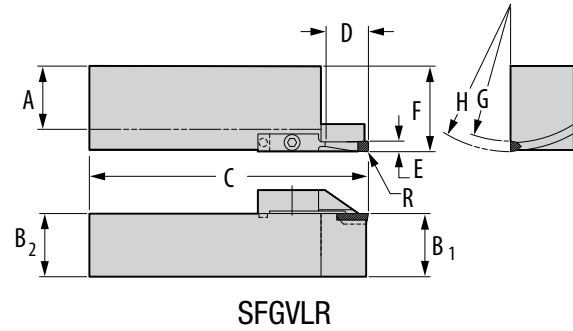
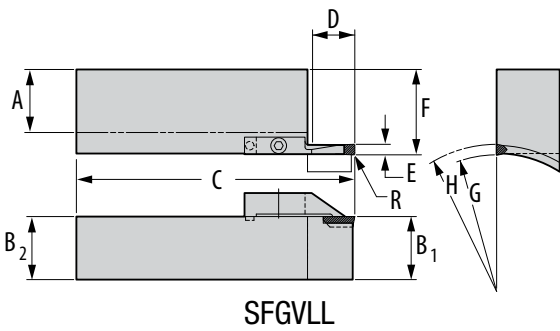

<b>SFGV__</b>	A	C	F
Drawing #	B <sub>1</sub>	D (depth of cut)	G (radius)
R (radius)	B <sub>2</sub>	E	H (radius)

# Straight Shank Holder

For Support Blades

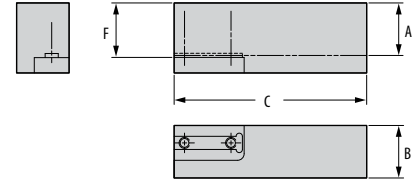



Part Number		Dimensions (mm)				Standard Components	*Tune-Up Kit
Right	Left	A	B	C	F	 Mounting Screw	Includes all Standard Components
M-411055	M-411056	25	25	125	26	FHCS M8-1.25x25mm	TK-02682
M-411059	M-411449	32	32	150	33	FHCS M8-1.25x25mm	TK-02682
M-411015	M-411016	40	40	200	41	FHCS M8-1.25x25mm	TK-02682

\* Tune-Up Kits include one complete set of Standard Components to allow you to refurbish the toolholder.

# Round Shank Holder

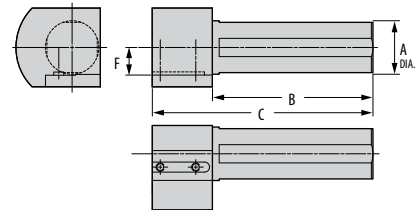
For Support Blades





Part Number		Dimensions (mm)				Standard Components	*Tune-Up Kit
Right	Left	A	B	C	F	 Mounting Screw	Includes all Standard Components
M-529678	M-529679	32	150	200	23	FHCS M8-1.25x25mm	TK-02682
M-529680	M-529681	40	150	200	27	FHCS M8-1.25x25mm	TK-02682
M-529682	M-529683	50	150	200	32	FHCS M8-1.25x25mm	TK-02682
M-529684	M-529685	60	150	200	37	FHCS M8-1.25x25mm	TK-02682

\* Tune-Up Kits include one complete set of Standard Components to allow you to refurbish the toolholder.

# KM Shank

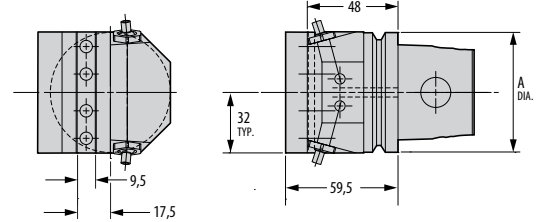
## Face Mount



Part Number	Dimensions (mm)		Standard Components	*Tune-Up Kit
Face Mount †	A		 Mounting Screw	Includes all Standard Components
M-SBH-KM50-F	50		FHCS M8-1.25x25mm	TK-02682
M-SBH-KM63-F	63		FHCS M8-1.25x25mm	TK-02682

High-pressure coolant – 1,500 PSI Max (100 bar)

\* Tune-Up Kits include one complete set of Standard Components to allow you to refurbish the toolholder.

† These tools based on KM63UT shank.

# KM Shank

## Side Mount

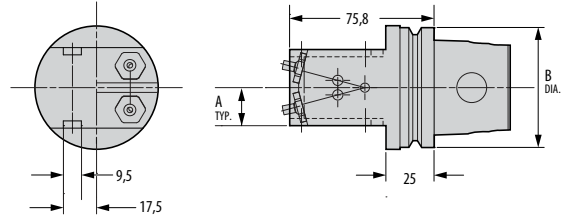

Part Number	Dimensions (mm)		Standard Components	*Tune-Up Kit
Face Mount †	A	B	 Mounting Screw	Includes all Standard Components
M-SBH-KM50-S	17,5	50	FHCS M8-1.25x25mm	TK-02682
M-SBH-KM63-S	20	63	FHCS M8-1.25x25mm	TK-02682

High-pressure coolant – 1,500 PSI Max (100 bar)

\* Tune-Up Kits include one complete set of Standard Components to allow you to refurbish the toolholder.

† These tools based on KM63UT shank.

# ISO 26623 Shank

## Face Mount

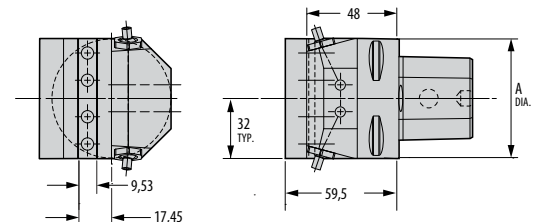

Part Number	Dimensions (mm)		Standard Components	*Tune-Up Kit
Face Mount	A		 Mounting Screw	Includes all Standard Components
M-SBH-C5-F	50		FHCS M8-1.25x25mm	TK-02682
M-SBH-C6-F	63		FHCS M8-1.25x25mm	TK-02682

High-pressure coolant – 1,500 PSI Max (100 bar)

\* Tune-Up Kits include one complete set of Standard Components to allow you to refurbish the toolholder.

# ISO 26623 Shank

## Side Mount

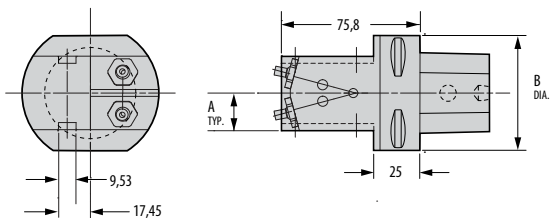

Part Number	Dimensions (mm)		Standard Components	*Tune-Up Kit
Face Mount	A	B	 Mounting Screw	Includes all Standard Components
M-SBH-C5-S	17,5	50	FHCS M8-1.25x25mm	TK-02682
M-SBH-C6-S	20	63	FHCS M8-1.25x25mm	TK-02682

High-pressure coolant – 1,500 PSI Max (100 bar)

\* Tune-Up Kits include one complete set of Standard Components to allow you to refurbish the toolholder.